



INSTRUCTION MANUAL

Pyranometer

MS-802/402/410/602

With Ventilator: MS-802F/402F

Version : 9



1. Index

1. Index	1
2. Important User Information	2
2-1. Contact Information	2
2-2. Warranty and Liability	2
2-3. About This Instruction Manual	3
2-4. Environment	3
2-5. ISO/IEC 17025:2005	4
2-6. CE Declaration	5
3. Safety Information	6
3-1. WARNING/CAUTION	6
3-2. HIGH VOLTAGE WARNING	6
4. Introduction	7
4-1. About the Pyranometer Series	7
4-2. Package Contents	9
5. Getting Started	10
5-1. Part Names and Descriptions	10
5-2. Setup	12
5-3. Measuring Solar Irradiance	14
6. Maintenance & Troubleshooting	16
6-1. Maintenance	16
6-2. Calibration and Measurement Uncertainty	17
6-3. Troubleshooting	19
7. Specifications	20
7-1. Pyranometer Specifications	20
7-2. Output Cables & Ventilation Unit Power Cables	24
7-3. Accessories List	24
APPENDIX	25
A-1. Radiometric Terms	25
A-2. Pyranometer Characteristics	26

2. Important User Information

Thank you for using EKO Products

Make sure to read this instruction manual thoroughly and to understand the contents before starting to operate the instrument. Keep this manual at safe and handy place for whenever it is needed.

For any questions, please contact us at one of the EKO offices given below:

2-1. Contact Information

EKO INSTRUMENTS CO., LTD.

Asia, Oceania Region

www.eko.co.jp	EKO INSTRUMENTS Co., Ltd.	
info@eko.co.jp	1-21-8, Hatagaya, Shibuya-ku	Tel: +81 (3) 3469-6713
	Tokyo, 151-0072 Japan	Fax: +81 (3) 3469-6719

Europe, Middle East, Africa Region

www.eko-eu.com	EKO INSTRUMENTS Europe B.V.	
info@eko-eu.com	Lulofsstraat 55, Unit 32,	Tel: +31 (0)70 3050117
	2521 AL, Den Haag, The Netherlands	Fax: +31 (0)70 3840607

North & South America Region

www.eko-usa.com	EKO INSTRUMENTS USA Inc.	
info@eko-usa.com	95 South Market Street, Suite 300	Tel: +1 408-977-7751
	San Jose, CA 95113 USA	Fax: +1 408-977-7741

2-2. Warranty and Liability

For warranty terms and conditions, contact EKO or your distributor for further details.

EKO guarantees that the product delivered to customer has been verified, checked and tested to ensure that the product meets the appropriate specifications. The product warranty is valid only if the product has been installed and used according to the directives provided in this instruction manual.

In case of any manufacturing defect, the product will be repaired or replaced under warranty. However, the warranty does not apply if:

- Any modification or repair was done by any person or organization other than EKO service personnel.
- The damage or defect is caused by not respecting the instructions of use as given on the product brochure or the instruction manual.

2-3. About This Instruction Manual

Copy Rights Reserved by EKO INSTRUMENTS CO., LTD. Making copies of whole or parts of this document without permission from EKO is prohibited.

This manual was issued: 2015/03/06
Version Number: 9

2-4. Environment

1. WEEE Directive 2002/96/EC (Waste Electrical and Electronic Equipment)

This product is not subjected to WEEE Directive 2002/96/EC however it should not be mixed with general household waste. For proper treatment, recovery and recycling, please take this product(s) to designated collection points.

Disposing of this product correctly will help save valuable resources and prevent any potential negative effects on human health and the environment, which could otherwise arise from inappropriate waste handling.

2. RoHS Directive 2002/95/EC

EKO Instruments has completed a comprehensive evaluation of its product range to ensure compliance with RoHS Directive 2002/95/EC regarding maximum concentration values for substances. As a result all products are manufactured using raw materials that do not contain any of the restricted substances referred to in the RoHS Directive 2002/95/EC at concentration levels in excess of those permitted under the RoHS Directive 2002/95/EC, or up to levels allowed in excess of these concentrations by the Annex to the RoHS Directive 2002/95/EC.

2-5. ISO/IEC 17025:2005

EKO Instruments Co. Ltd. calibration laboratory is accredited by Perry Johnson Laboratory Accreditation, Inc. (PJLA) to perform pyranometer and pyrhelimeter calibrations in accordance with the requirements of ISO/IEC17025, which are relevant to calibration and testing.

EKO is a unique manufacturer who can offer calibration service for pyranometers and pyrhelimeters in-house. Based on the applied calibration methods EKO provides the best quality solar sensor calibrations compliant to the international standards defined by ISO/IEC17025 / 9847 (Indoor method) and ISO9059 (Outdoor method) (Certification: L13-94-R2 / www.pjilabs.com)

ISO/IEC17025 provides a globally accepted basis for laboratory accreditation that specifies the management and technical requirements. With calibrations performed at the EKO Instruments laboratory we enable our customers to:

- Clearly identify the applied calibration methods and precision
- Be traceable to the World Radiation Reference (WRR) through defined industrial standards:
 - ISO9846 Calibration of a pyranometer using a pyrhelimeter
 - ISO9847 Calibration of field pyranometer by comparison to a reference pyranometer
 - ISO9059 Calibration of field pyrhelimeters by comparison to a reference pyrhelimeter
- Obtain repeatable and reliable calibration test results through consistent operations

Our clients will obtain a high level of confidence when purchasing an ISO/IEC17025 calibrated sensor. Our Accredited lab is regularly re-examined to ensure that they maintain their standards of technical expertise.

2-6. CE Declaration



IMPORTANT USER INFORMATION



DECLARATION OF CONFORMITY

We: EKO INSTRUMENTS CO., LTD
1-21-8 Hatagaya Shibuya-ku,
Tokyo 151-0072 JAPAN

Declare under our sole responsibility that the product:

Product Name: Pyranometers
Model No.: MS-802, MS-402, MS-410, MS-602

To which this declaration relates is in conformity with the following harmonized standards of other normative documents:

Harmonized standards:

EN 61326-1:2006 Class A (Emission)
EN 61326-1:2006 (Immunity)

Following the provisions of the directive:

EMC-directive: 89/336/EEC
Amendment to the above directive: 93/68/EEC

Date: Oct. 08, 2008

Position of Authorized Signatory: Deputy General Manager of Quality Assurance Dept.

Name of Authorized Signatory: Shuji Yoshida

Signature of Authorized Signatory: 

3. Safety Information

EKO products are designed and manufactured under the consideration of the safety precautions. Please make sure to read and understand this instruction manual thoroughly in order to be able to operate the instrument safely and in the correct manner.



WARNING CAUTION

Attention to the user; pay attention to the instructions given on the instruction manual with this sign.



HIGH VOLTAGE WARNING

High voltage is used; pay special attention to instructions given in this instruction manual with this sign to prevent electric leakage and/or electric shocks.



3-1. WARNING/CAUTION

1. Setup

- The installation base or mast should have enough load capacity for the instrument to be mounted. Fix the pyranometer securely to the base or mast with bolts and nuts; otherwise, the instrument may drop due to gale or earthquake which may lead to unexpected accidents.
- Make sure the instrument and the cables are installed in a location where they will not get soaked.

2. Glass Dome

Be careful with glass domes when handling instruments. Strong impact to this part may damage the glass and may cause injuries by broken glass parts.

3. Ventilation Unit

Be careful when handling the ventilation unit during operation. Fingers or clothing may get caught into the ventilation fan, which can lead to serious injuries.



3-2. HIGH VOLTAGE WARNING

Power Supply (for the models with ventilation unit)

- For AC versions of the ventilation units make sure to ground the earth wire of the power cable. When the power supply is not grounded, it may cause noise on the data and lead to measurement errors. Furthermore, grounding the earth wire will prevent electric shocks and current leakage.
- Make sure to check the power supply voltage and type (AC/DC) before connecting the fan unit to the power supply. Connecting the fan unit to other power supplies than specified will lead to damage and accidents

4. Introduction

EKO started to develop its first pyranometer in 1955. This traditional product range has been improved and extended ever since. During the last decade, EKO introduced an extended range of high-precision thermopile-type pyranometers. The current high-quality broad-band pyranometer series is designed to be used in any outdoor environments and is perfectly suited for the most demanding field reference applications in the photovoltaic and meteorological markets. EKO pyranometers are widely used around the world and meet the highest ISO and WMO standards. The highest class ISO Secondary Standard MS-802 pyranometer is designed for the most demanding applications in field research and monitoring of global and diffuse solar radiation.

EKO has over 50 years of experience in developing and manufacturing solar radiation sensors. This know-how is integrated into the EKO pyranometer-series which provides a fully-sealed and all-weather proof radiometer built to measure the global solar irradiance in unattended outdoor installations throughout the year. All EKO instruments provide a perfect balance between cost-effectiveness and quality.

4-1. About the Pyranometer Series

EKO offers four types of thermo-pile based pyranometers to cover all three ISO9060 standard classes, which are “Secondary Standard”, “First Class” and “Second Class”. With this wide range of instrument types, EKO pyranometers can meet all possible application requirements, ranging from PV module efficiency measurements to climatology research and material durability testing. In the following paragraphs, the four instrument types are described individually.

1. MS-802/MS-802F

The MS-802 ISO9060 Secondary Standard pyranometer is used widely as a reference sensor to measure the global broad-band solar radiation with a high accuracy. Its robust brass housing makes it a durable sensor suitable to be used in harsh environments. The MS-802 is used as a standard for PV research and climatology studies around the world.

MS-802 pyranometer has the following key features:

- Fast Response time (95% signal level in < 5s)
- Temperature compensated over a wide temperature range
- High quality optical glass domes providing accurate cosine response
- MS-802F is a MS-802 pyranometer with ventilation system that minimizes the negative effects of frost, snow and dust on the measurements

2. MS-402/MS-402F

The design of the MS-402 ISO First Class Pyranometer is very similar to that of the ISO9060 Secondary Standard MS-802. Its robust brass housing makes it a durable sensor suitable to be used in harsh environments for routine global irradiance measurements. The MS-402 can be used as multi-purpose high-quality monitoring sensor in the PV and meteorological markets. A special feature of the MS-402 is its full temperature compensation.

Key features of MS-402 are:

- Response time (95% signal level in < 8s)
- Temperature compensated over a wide temperature range
- MS-402F is a MS-402 pyranometer with ventilation system that minimizes the negative effects of frost, snow and dust on the measurements

3. MS-410

The MS-410 is perfectly suited for sampling 10-minute averages of the solar radiative flux in horizontal or tilted measurement configurations. It is fully compliant with the ISO9060 First Class norm. The practical light-weight anodized aluminum housing, the highly efficient sensor coating and the two precision-machined hemispheric glass domes provide an excellent performance characteristics of the MS-410. The EKO MS-410 is a perfect balance between cost-effectiveness and quality.

Key features of MS-410 are:

- Light weight aluminum housing
- Double glass dome minimizes thermal zero offsets
- Typical network sensor

4. MS-602

Within the EKO pyranometer-series the, MS-602 pyranometer is the smallest thermopile-based pyranometer. To measure the entire broad-band solar irradiance the MS-602 provides the most economic measurement solution. The 9060 Second Class norm features an exceptionally low temperature dependency that is commonly found only in higher-class pyranometers.

Key features of MS-602 are:

- Most economic solution
- Low temperature dependency
- Compact all-weather sensor

4-2. Package Contents

Check the package contents first; if any missing parts or any damage is noticed, please contact EKO immediately.

Table 4-1. Package Contents

Contents	MS-802/402/410	MS-802F/402F	MS-602
Output Cable*	○	○	○
Power Cable* for Ventilation Unit	—	○	—
Pyranometer	○	○	○
Sun Screen	○	○	—
Ventilation Unit	—	○	—
Instruction Manual	○	○	○
Calibration Certificate	○	○	○
Quick Start Guide	○	○	○
Fixing Bolts (M6) x 2	○ (Bolt Length: 75mm)	○ (Bolt Length: 100 mm)	○ (Bolt Length: 50 mm)
Washers (M6) x 4	○	○	○
Nuts (M6) x 2	○	○	○

*Standard length is 10m for both signal cable and power cable. For different length of cables (e.g. to meet your application needs) please contact EKO or your local distributor. Please note, that there are 2 types of ventilation units: AC or DC.

5. Getting Started

5-1. Part Names and Descriptions

Each part name and its main function is described below.

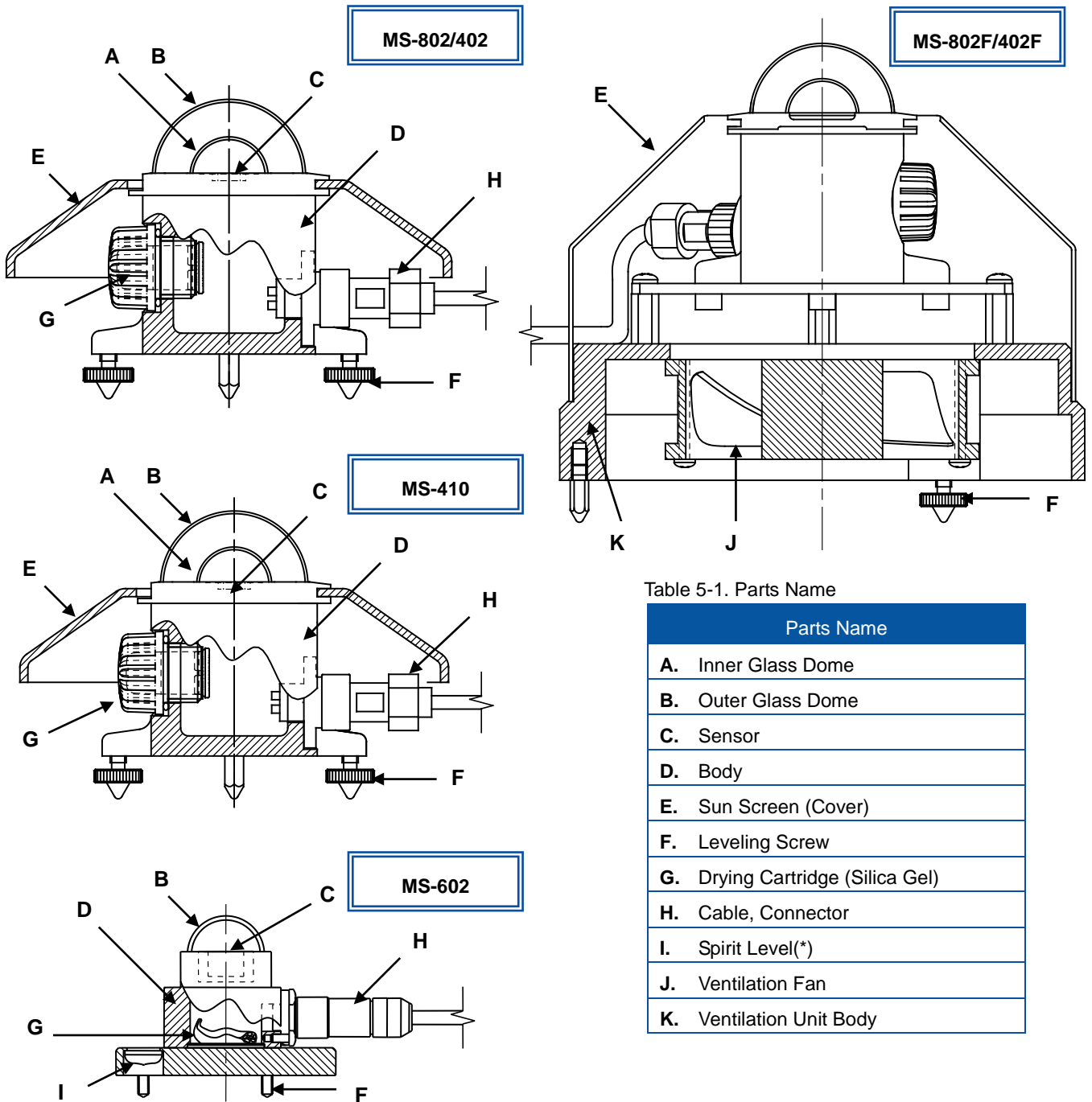

Table 5-1. Parts Name

Parts Name
A. Inner Glass Dome
B. Outer Glass Dome
C. Sensor
D. Body
E. Sun Screen (Cover)
F. Leveling Screw
G. Drying Cartridge (Silica Gel)
H. Cable, Connector
I. Spirit Level(*)
J. Ventilation Fan
K. Ventilation Unit Body

*Spirit level is not shown on the drawings for MS-802/402/410 due to its position on the cross-section drawings.

Figure 5-1. Pyranometer Parts Name

1. Inner and Outer Glass Domes

A glass dome creates a sealed environment for the detector and protects it against dirt, rain and wind. Besides the mechanical protection, the optical properties of the glass dome(s) minimize the undesired influence of long wave radiation on the shortwave radiation: the domes of the EKO pyranometers are only transparent for radiation emitted by the sun. Hence they block the undesired infrared radiation emitted by the Earth's atmosphere. The glass domes of all EKO thermopile pyranometers permit to measure the cosine-weighted global solar irradiance over the entire hemisphere, i.e. with a field-of-view of 180 degree.

2. Sensor

The thermopile detector of the pyranometers generates a voltage signal that is proportional to the solar irradiance absorbed on the black surface of the detector. The thermopile detector, which is the heart of the sensor, determines the majority of the measurement properties (e.g. response time, zero offset B, non-linearity, sensitivity, etc.). EKO thermopile detectors are very stable in time due to the high stability of the black absorber material.

3. Sun Screen/Cover, Sensor Body, and Spirit Level

EKO pyranometers (except MS-602) have a sun screen (or a cover for models with ventilation unit) to prevent excessive body temperature increase generated by direct sun light. The solid pyranometer body is made of a combination of non-ferroalloy and ferroalloy metals which are resistant against environmental impact, heat, rain and dusts.

The integrated spirit level is used to setup and maintain the sensor in a horizontally leveled position.

4. Drying Cartridge

A drying cartridge filled with silica gel is used to keep the sensor volume dry. The dry air inside the sensor body prevents condensation of humidity on the inside of the glass dome. The silica gel (desiccant) of the insert-able drying cartridge can be easily replaced. (*MS-602 does not have an accessible drying cartridge.)

5. Cable and Cable Connector

All pyranometers are shipped with a 10 meter long output cable as standard length*. The cables are connected to the pyranometers by a rugged and sealed connector. The loose ends of the cables are fitted with pin terminals for easy connection to data acquisition devices. The special cable and connector material is resistant to temperature and humidity fluctuations. The humidity and UV resistant cable and connector are suitable to be used in harsh outdoor environmental conditions for a long period of time. The ventilation unit also comes with a power cable (either AC power or DC power types).

*If longer cables are required, please contact EKO Instruments or your distributor.

6. Ventilation Unit

The ventilation unit is an optional accessory for the MS-802 and the MS-402. The glass domes of a pyranometer with a ventilation unit will remain almost always free of frost, snow, dew and dust deposition. Therefore, measurements obtained with pyranometer and ventilation unit are in general more accurate than the measurements obtained with the pyranometer without ventilation unit. However, periodic maintenance, such as cleaning the glass dome, is nevertheless recommended, even when using a ventilation unit.

5-2. Setup

In order to obtain representative measurements from pyranometers, several criteria with respect to setup and mounting of the instruments have to be considered*:

The ideal mounting position for pyranometers is a location which has a full hemispheric field-of-view without any obstructions (such as buildings, trees, and mountain). In practice, it might be difficult to find such locations. Therefore, some practical recommendations on how to minimize undesired effects of reflecting or obstructing surfaces are given next:

- Select a mounting position which it is free from obstructions at 5° above horizon.
- The setup location should be easily accessible for periodic maintenance (glass dome cleaning, desiccant replacement, etc.).
- Avoid surrounding towers, poles, walls or billboards with bright colors that can reflect solar radiation onto the pyranometer.
- A strong physical impact to the pyranometer can lead to product damage and/or may cause changes to the sensitivity.

*See also the attached Quick Start Guide for comprehensive setup instruction details.

1. Installing at Horizontal or Tilted Positions

- 1) Check the installation base where the pyranometer has to be mounted and make sure it has two fixing holes with the appropriate pitch. The pitch sizes of the fixing holes are as follows (in mm):

Table 5-2. Fixing Hole Pitch and Bolt Size for Pyranometers

	MS-802/402/410	MS-802F/402F	MS-602
Fixing Hole Pitch	80 mm	160 mm	60 mm
Fixing Bolt Size	M6 x 75 mm	M6 x 100 mm	M6 x 50 mm

- 2) Setup the pyranometer with the signal cable connector facing the nearest Earth's pole.
In the Northern hemisphere, the connector should be orientated North, in the Southern hemisphere, the connector should be orientated South.
- 3) Remove the sun screen by turning it **clockwise**.
When removing or attaching the sun screen, **always turn the sun screen clockwise**. If it is turned counterclockwise, the glass dome part will become loose and moisture may leak into the housing of the pyranometer, which may cause condensation and degradation of the instrument.
- 4) Adjust the pyranometer in a horizontal position by using the 2 leveling screws (MS-802/402, MS-802F/402F and MS-410) or 3 leveling screws (MS-602) and observing the air bubble in the spirit level while manipulating the leveling screws. The instrument is leveled horizontally if the air bubble is in the center ring.

- 5) If the pyranometer is not leveled properly, the pyranometer readings are affected by cosine and azimuth errors. Periodically check the spirit level and adjust the pyranometer's position if necessary.

If the pyranometer has to be installed in a tilted-angle mounting position then proceed in two steps as follows:

First, place the pyranometer on a flat installation base which is in a truly horizontal position then adjust the instrument's leveling screws by observing the air bubble in the spirit level while manipulating the leveling screws; the instrument is leveled horizontally if the air bubble is in the center ring.

Second, mount the pyranometer with the adjusted leveling screws in the desired tilted position.

*When installing the instrument, do not remove the leveling screws; if the leveling screws are removed, it may cause abnormal output values due to the thermal effects from the mounting part.

- 6) Fasten the pyranometer to the base with the 2 bolts (included) and put the sun screen back on the pyranometer. (Always turn the sun screen **clockwise**).





2. Wiring

- 1) To extend the cable life time, make sure that the cables are not exposed to direct sun light or rain/wind by lining the cable through a cable conduit. Cable vibrations will potentially cause noise in the output signal. Fasten the cable so that the cable does not swing or move by wind blowing.

Exposure of the signal cable to excessive electromagnetic emissions can cause noise in the output signal as well. Therefore the cable should be lined at a safe distance from a potential source generating EM noise, such as an AC power supply, high voltage lines or telecom antenna.

- 2) Connect the output cable to the pyranometer.
Make sure to check the pin layout of the connector before connecting the cable. If the connector cannot be easily inserted, DO NOT use any force as it will damage the connector. Visually check the pin layout again before retrying to insert the connector.
- 3) Connect the other end of the output cable to the signal tester or data logger as follow:

Table 5-3. Output Cable Pin Layout

MS-802(F)		(+) Plus Output (White Wire)
MS-402(F)		(-) Minus Output (Black Wire)
MS-602		(+) Plus Output (White Wire)
MS-410		(-) Minus Output (Black Wire)

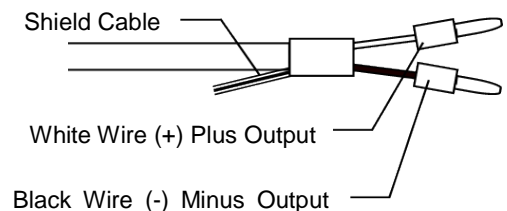

Figure 5-2. Cable Connection

- 4) Check the output voltage.
If a large noise is seen in the output voltage signal, try to connect the shield to (-) minus input terminal.
*Connecting shield cable does not mean the noise will be removed, thus make sure to keep away from possible source of noise when wiring.

- 5) When a pyranometer with a ventilation unit is installed, connect the power cable. Make sure to ground the earth terminal (green cable) attached to the power cable (AC versions only).

*When the power is switched on, check whether the ventilation unit is working properly by placing your hand above the pyranometer to feel the air stream.

5-3. Measuring Solar Irradiance

In order to determine the global broad-band solar irradiance, the measured output voltage [mV] of the pyranometer has to be converted by the calibration factor into the units of the solar radiative flux, which is Watts per meter squared (W/m^2). The output can be measured with a high-resolution (at least $5\mu V$) measuring instrument, such as a voltmeter or data logger. A signal range of about 10mV to 20mV should be available in order to prevent over range of the measured voltage signals. If the global broad-band solar irradiance is measured continuously, it is recommended to use an accurate data logger with sufficient data storage capacity and data manipulation functions. Some recommendations for setting up a continuous measurement system are given in the following:

- 1) Measurement range settings:

If the measurement range can be selected on the data acquisition system, select the measurement range which can accurately measure the signal over a range of 0 to 10mV (0 to 20mV for MS-410). Under the assumption that the global broad-band solar irradiance does not exceed $1,400W/m^2$ (in both horizontal and tilted measurement positions) the signal level of the pyranometer output Voltage will remain below 10mV (20mV for MS-410). This maximum output Voltage can be calculated by multiplying the maximum solar irradiance with the calibration factor (e.g. when the sensitivity of the MS-802 pyranometer is about $7\mu V/W \cdot m^{-2}$ or $0.007mV/W \cdot m^{-2}$, the maximum output voltage is about $1,400W/m^2$ times $0.007mV/W \cdot m^{-2} = 10.5mV$).

- 2) Calculate the global broad-band solar irradiance [W/m^2].

The global solar irradiance in Watts per meter squared (W/m^2) is obtained when the output voltage E [μV] is divided by the sensitivity of the pyranometer S [$\mu V/W \cdot m^{-2}$]. This calculation is expressed by the following formula:

$$I (W/m^2) = \frac{E (\mu V)}{S (\mu V/W \cdot m^{-2})}$$

*The sensitivity S for the pyranometer is stated on the calibration certificate and the product label.

Sampling Rates and Averaging/Integrating of Measurement Data

In continuous operation mode the pyranometer is usually connected to a programmable data logger system. Hence, sampling rates and data reduction methods can be defined right at the beginning of the data acquisition process.

To explore the maximum measurement capacity of the pyranometer and in order to limit the data volume, the sampling rate and the averaging/integrating period have to be chosen carefully. Choosing the right sampling rate depends on the pyranometer's response time. Note that the EKO pyranometer-series have different response times, ranging from 5 seconds (MS-802) to 17 seconds (MS-602). The response time that is given in the specifications of the EKO pyranometers states the amount of time which is necessary to reach 95% of the final measurement value. It is also possible to define a 63.2% response (which is equal to $1-1/e$). This time constant, represented by the symbol τ , is 3 times smaller than the values specified by EKO.

The recommended⁽¹⁾ sampling rate for pyranometers is smaller than τ . So, for EKO pyranometers, the sampling rates that have to be programmed in the data logger systems should not exceed the values as given in table 7.1.

Performing averaging and/or integration of measurement data can be meaningful to, e.g., reduce the data volume or to meet application-specific requirement. Note that shorter sampling rates allow to use shorter averaging/integration times (example for MS-802: 10 second sampling rate, 1 minute averaging period). It could also be meaningful to store not only average values, but to keep track of all statistical values during the averaging period, namely: average, integral, minimum and maximum values, and standard deviation.

As a general recommendation, the averaging/integration period should be as short as possible, but long enough to reduce the data volume to store the processed data safely.

⁽¹⁾"Guide to Meteorological Instruments and Methods of Observation", WMO reference document Nr. 8.

Examples:

The total daily radiant energy in Joule per meter squared (J/m^2) is obtained by integrating the solar irradiance over time. To calculate the total daily radiant energy in Joule per meter square (J/m^2), multiply the averaged solar irradiance \bar{I} [W/m^2] by the averaging interval period (s). Then sum-up the total data number (n) of averaged data points in one day. Its physical unit is expressed with [J/m^2] and can be calculated with $J = W \cdot S$

$$DTI = \sum_{k=1}^n \bar{I}_k \times t^k$$

6. Maintenance & Troubleshooting

6-1. Maintenance

Measurements of solar irradiance using EKO pyranometers yield highly accurate results if the glass dome and the condition of the instrument are maintained properly. Furthermore, regular maintenance and scheduled re-calibrations can extend the lifetime of EKO pyranometers over 10th of years. However, environmental conditions, such as for instruments mounted near highly frequented traffic lanes or airports, may have a deteriorating effect on the materials. Therefore, proper maintenance is needed and has to be adapted to the local environmental conditions.

The following table describes the common maintenance tasks that should be performed on a regular basis:

Table 6-1. Maintenance Items

Maintenance Item	Frequency	How To	Effect
Clean Glass Dome	Several times per week (at least once per week)	Keep the glass dome clean by wiping it with a soft cloth and alcohol.	If the glass dome gets soiled (by accumulation of dirt) the detector output will be affected due to a change in transmittance. This dirt can either be removed manually (using a soft cloth and alcohol) or it is washed off by rain (self cleaning effect).
Check Glass Dome Condition	Weekly	Check for cracks and scratches on the glass dome and the rim.	May lead to water leakage due to rain/dew which causes damage of the detector inside the pyranometer.
Check Spirit Level Bubble	Weekly	Verify if the pyranometer is leveled by checking the bubble is in the center ring of spirit level. (When the pyranometer is setup in horizontal position)	If a pyranometer in the horizontal measurement position is not leveled correctly an additional cosine/azimuth error will be introduced.
Check Cable Condition	Weekly	Verify if the cable connector is properly connected, tightened to the instrument, and how cable is lined; make sure the cable is not swinging by wind.	A disconnected cable will cause sporadic reading errors or failure of operation. If the cable is damaged, it may lead to noise or electric shock (ventilator AC power cable).
Check Setup Base Condition	Weekly	Check if the instrument is tightened properly to the mounting base plate and the base plate and/or table is securely fastened in a proper condition.	Loose instruments and/or mounting plates can lead to damages of the instruments and/or injury.
Check Silica Gel	Weekly	Verify that the color of the silica gel is dark blue (dark blue = okay). If the color of the silica gel turns into a reddish color then replace it with new silica gel.	With moisture saturated silica gel gives condensation inside the dome which leads to a lower detector output or damage.

Table 6-1. Maintenance Items -- Continued

Maintenance Item	Frequency	How To	Effect
Recalibration	Every 2 Years	To maintain the best possible measurement accuracy, regular recalibration of the pyranometer is recommended. Contact EKO for more details and requests for a recalibration and maintenance service.	Due to natural aging of materials the detector properties of the pyranometer can change in time which affects the sensor sensitivity.

6-2. Calibration and Measurement Uncertainty

It is recommended to recalibrate EKO pyranometers once every 2 years in order to maintain the good quality of the solar radiation measurements. Below explains about the calibration methods of EKO pyranometers and their calibration uncertainty. For further information about recalibration and maintenance procedures, please contact EKO.

1. Calibration Method

EKO Pyranometers series are calibrated indoors against a 1000W/m² AAA class solar simulator radiation source. During a calibration sequence, the incidence irradiance [W/m²] is alternately measured with the reference pyranometer of the same model. The sensitivity figure of the production pyranometers is determined by calculating the output ratio multiplied by the sensitivity figure of the reference model.

As the calibration procedure, alternately place both reference and production pyranometers in the center of the light in horizontal position, at the same distance from the solar simulator and measure the output from each pyranometer.

Measurement Uncertainty of Indoor Calibration

The calibration repeatability and precision will be very high since the measurement conditions such as ambient temperature and solar simulator irradiance are very stable during the calibration sequence. The repeatability achieved by the indoor method is better than 99%. The expanded calibration uncertainty depends on the pyranometer model and is written on the calibration certificate.

2. Measurement Uncertainty

To estimate measurement uncertainties of pyranometers, some understanding of the physical properties of thermo-electric sensors is required. A brief look at the instrument's specification list gives an impression of the many parameters that affect the radiation measurements. Fortunately all these individual error sources, which have a small magnitude, will rarely affect the measurement at the same time. However, it is very difficult to calculate the combined measurement uncertainty because it is nearly impossible to isolate the individual measurement conditions to determine the corresponding errors. This illustrates the difficulty and complexity of the measurement uncertainty calculation. Some practical guidelines to assess the measurement errors are given next.

- 1) Use the relative measurement uncertainty of the calibration factor to determine the measurement error of each single measurement.
- 2) Make averages of a large number of individual measurements (for example 1-second

measurements averaged over 5 minutes).

- 3) Adopt reported best-practice measurement uncertainties (see for example [Diffuse IOP], [Pyrheliometer IOP]).

Traceability

Internal reference pyranometer maintained at EKO is traceable to the absolute cavity which is directly compared against the WRR (World Radiometric Reference) Primary Standard (Absolute Cavity) managed at PMOD (Davos, Switzerland). The logger system used for the calibration measurement is traceable to JEMIC (Japan Electric Meters Inspection Cooperation).

Internal reference pyranometer is calibrated directly compared against the pyrheliometer, which is measured against the EKO absolute cavity, and 2 units of internal reference pyranometers by Shading Method ([A New Method for Calibrating Reference and Field Pyranometers (1995)] Bruce W Forgan) every one year.

EKO absolute cavity is directly traceable to WRR by comparing against WRR every 5 years.

6-3. Troubleshooting

Read the following in case of trouble with the instrument. If any questions should remain, please contact EKO for further technical support.

Table 6-3. Troubleshooting

Failure	Action
There is no output.	Make sure that the sensor cable is connected properly to the instrument. To verify the connection, measure the impedance of output cable (between the “+” and the “-” wires) and check if the measured impedance is within the proper range as shown on the specification. (See 7. Specifications)
Output value is too low	The glass dome maybe soiled with rain or maybe contaminated. Clean the glass dome with a soft cloth.
Output signal during night time is not zero	Pyranometers generate an output signal which is proportional to the temperature differences between the sensor’s so-called hot and cold junctions; hence, small differences in temperatures between, for example, the housing and the sensor generate in some cases a small voltages. This is an instrument-intrinsic phenomenon, which has no significance related to the quality of the instrument.
Silica gel has changed its color (not applicable for MS-602)	Replace the silica gel. Remove the drying cartridge from the pyranometer housing, open the cap at the inner end of the small tube and replace the silica gel.
Unusual noise coming from the ventilation unit (only applicable to pyranometers with ventilation system)	Possibly some objects, such as leaves or trash, got stuck in the ventilation unit. Stop the ventilation unit and check for any objects near or in the ventilator. The noise of the ventilation unit may increase due to aging. In such a case, contact EKO for replacement.

7. Specifications

7-1. Pyranometer Specifications

1. Specifications

The comparison table below, Table 7-1, shows typical values for the characteristic parameters of the EKO Pyranometers and the corresponding values of the ISO 9060 norm. Other specifications are listed on the Table 7-2.

Table 7-1. Pyranometer specifications

Characteristics	Secondary - standard	MS-802 / MS-802F	First - class	MS-402 / MS-402F / MS-410	Second - class	MS-602
Response Time (Output 95%)	<15 Sec	Approx. 5 Sec	<30 Sec	Approx. 8 Sec Approx. 18 Sec	<60 Sec	<17 Sec
Zero Off-Set A	<7 W/m ²	<6 W/m ²	<15 W/m ²	<6 W/m ² <6 W/m ²	<30 W/m ²	<10 W/m ²
Zero Off-Set B	<2 W/m ²	<2 W/m ²	<4 W/m ²	<2 W/m ² <2 W/m ²	<8 W/m ²	<6 W/m ²
Long-Term Stability	<0.8 %	<0.5 %	<1.5 %	<0.5 % <1.5%	<3 %	<1.7 %
Non-Linearity	<0.5 %	<0.2 %	<1 %	<0.2 % <1%	<3%	<1.5 %
Directional Response	<10 W/m ²	<10 W/m ²	<20 W/m ²	<20 W/m ² <20 W/m ²	<30 W/m ²	<25 W/m ²
Spectral Sensitivity	<3 %	<1 %	<5 %	<1 % <1 %	<10 %	<1 %
Temperature Response	<2 %	<1 %	<4%	<1 % <2 %	<8%	<2 %
Tilt Response	<0.5 %	<0.2 %	<2 %	<0.2 % <2 %	<5 %	<2 %
Wavelength range	---	285 to 3000 nm	---	285 to 3000 nm	---	285 to 3000 nm

Table 7-2. Other Specification

Characteristics	MS-802 / MS-802F	MS-402 / MS-402F	MS-410	MS-602
Field of View	2π (sr)			
Operating Temperature	-40 to +80°C			
Operating Temp. with Ventilation	-40 to +50°C (-10 to +50°C)		-	
Weight (with ventilation)	1.4kg (3kg)		830g	230g
Paint	Munsell Color: N-9.5 White, Baked		White Anodized	
Sensitivity	Approx. 7.00μV/W·m ²		7.00 to 14.00 μV/W·m ²	Approx. 7.00μV/W·m ²
Impedance	Approx. 500Ω		20 to 140Ω	20 to 140Ω
Output Cable (outer diameter)	0.5mm ² x 2 pins (φ6.7mm)		0.3mm ² x 2 pins (φ4.8mm)	
Output Cable Terminal	Pin-Terminal (1.25-11S)		Pin-Terminal (1.25-11S)	
*Ventilation Supply Power:	AC	120V, 220V, 240V, 16W @ 50Hz/15W @ 60Hz		-
	DC	12V or 24V		-
Power Supply Cable (outer diameter)	0.75mm ² x 3 pins (φ6.8mm)		-	
DC Power Supply Cable Terminal	Ring Terminal (1.25-4)		-	

*There are 2 different types of supply powers for the ventilation; please specify when purchasing.

2. Dimensions & Weights

Below table and figures give the pyranometer dimensions for each model.

Table 7-3. Dimensions

	MS-802/402	MS-410	MS-602	MS-802F/402F
A. Fixing Hole Pitch	80 mm	80 mm	60 mm	160 mm
B. Body Height	65 mm	68 mm	45 mm	140 mm
C. Leveling Screw Height	*16 mm	*16 mm	> 0mm	*16 mm
D. Width (including Sun Screen/Cover)	φ160 mm	φ160 mm	φ78 mm	φ200 mm
E. Overall Height (approx.)	108mm	111mm	66mm	183mm

* Length of fixed leg is indicated

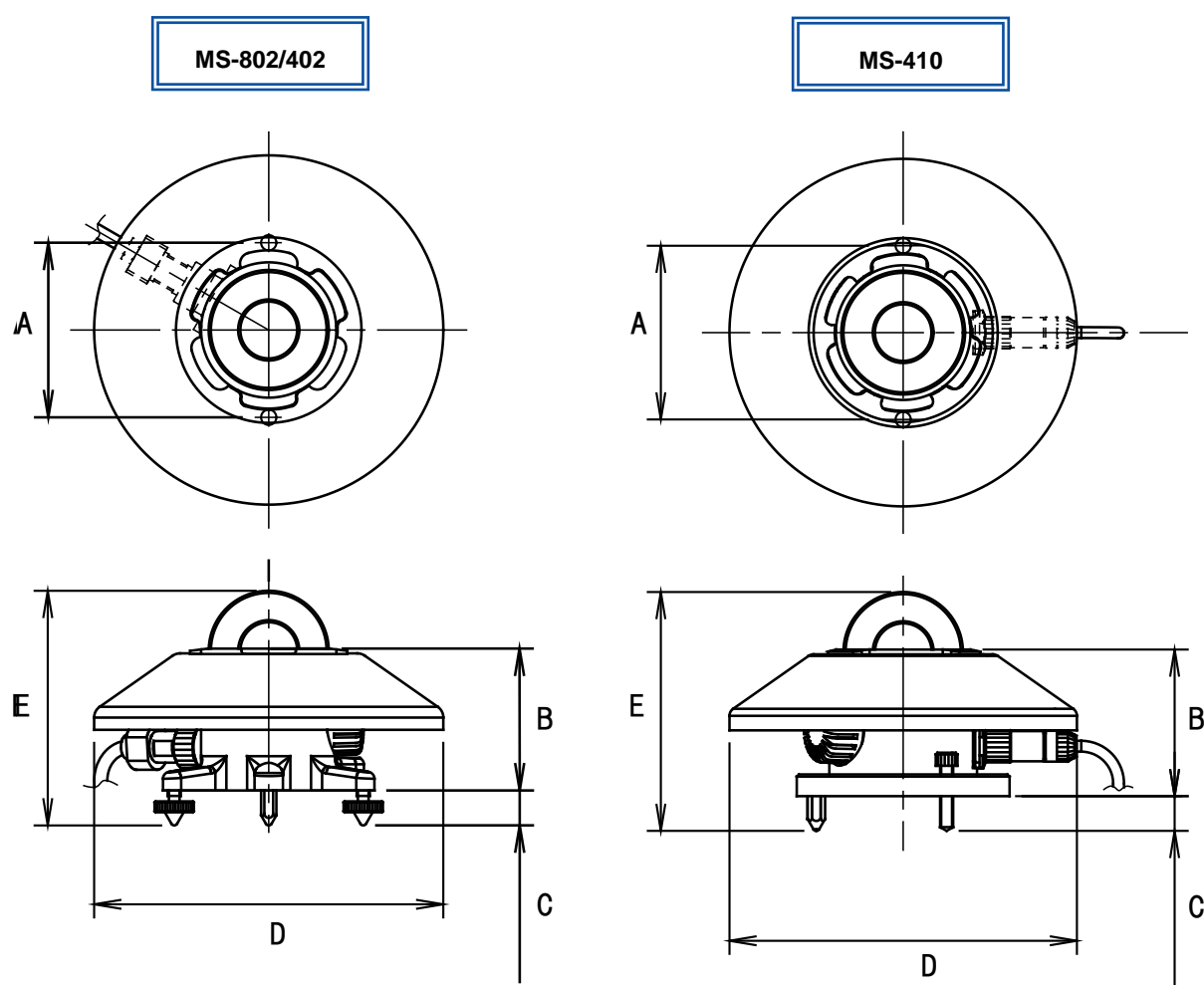
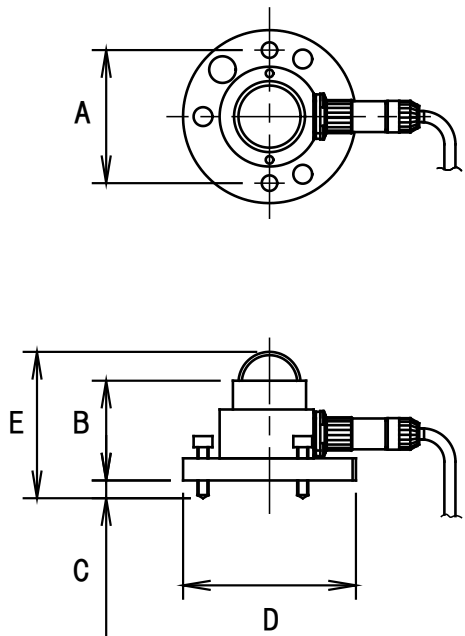

Figure 7-1. Outer Dimensions of Each Pyranometer Model

MS-602



MS-802F/402F

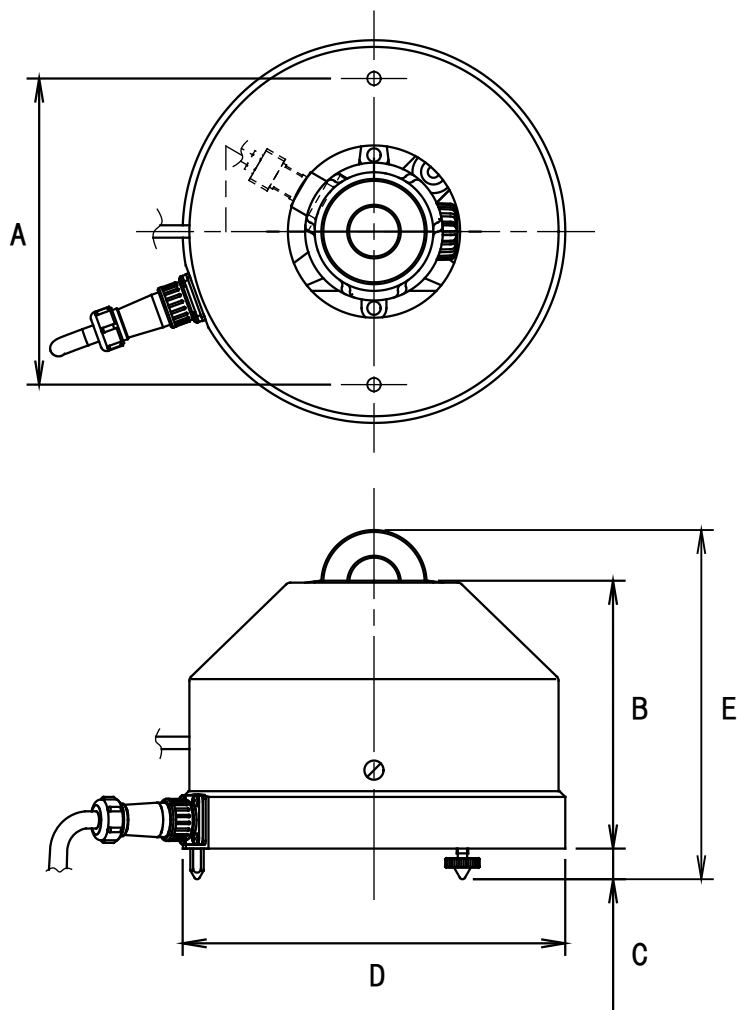
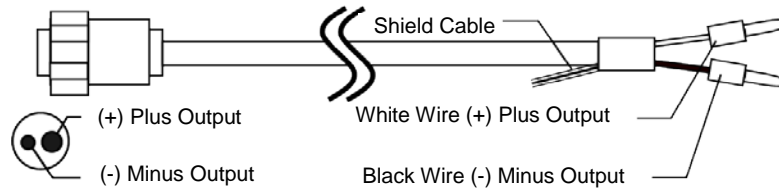

Figure 7-2. Outer Dimensions of Each Pyranometer Model

7-2. Output Cables & Ventilation Unit Power Cables

1. MS-802(F)/402(F) Output Cable



2. MS-410/602 Output Cable

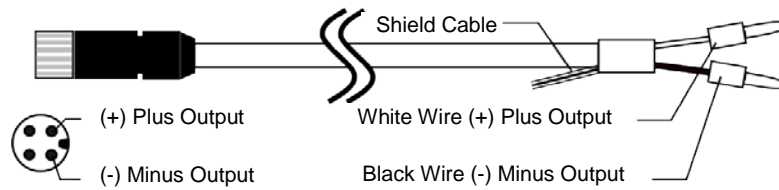

3. Ventilation Unit DC Power Supply Cable

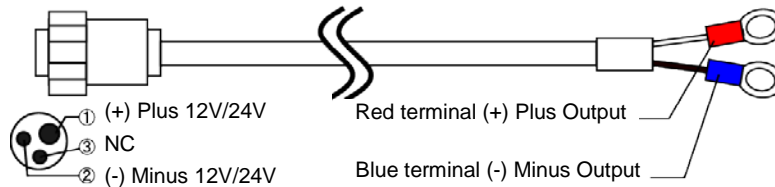

4. Ventilation Unit AC Power Supply Cable

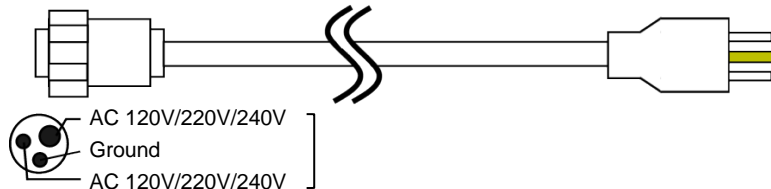

Figure 7-3. Output Cables and Power Cables

7-3. Accessories List

Table 7-4. Accessories List

Option Items	Remarks
Output Cable	20m, 30m, 50m (with Fork or Pin terminals)
Power Cable	20m, 30m, 50m for 120V, 220V, 240VAC or 12V, 24VDC power supply
Silica Gel for replacement (not applicable for MS-602)	Silica gel (desiccants) bottle (500g)

A-1. Radiometric Terms

Table A-1. Definitions of Terms

Hemispheric Solar Irradiance	Cosine-weighted solar irradiance received over a solid angle of 2π sr on a plane surface, expressed in units of W/m^2 or kW/m^2 .
Global Solar Irradiance, Global Horizontal Irradiance (GHI)	Hemispherical solar irradiance received on a horizontal plane surface, expressed in units of W/m^2 or kW/m^2 .
Direct Solar Irradiance, Direct Normal Irradiance (DNI)	Normal-incidence solar irradiance received over a small solid angle which includes the circum solar irradiance, expressed in units of W/m^2 or kW/m^2 .
Diffused Solar Irradiance, Diffused Horizontal Irradiance (DHI)	Hemispherical solar irradiance without the direct solar irradiance, i.e. indirect irradiance of the scattered solar radiation (by air molecules, aerosol particles, clouds, etc.), expressed in units of W/m^2 or kW/m^2 .
Pyranometer	A radiometer designed to measure the hemispheric solar irradiance over the wavelength range of about 300 to 3,000nm.
Pyrheliometer	A radiometer which measures the direct solar irradiance over a certain solid angle including the circumsolar irradiance.
World Radiation Reference (WRR)	Radiometric reference instrument system which has an uncertainty of less than $\pm 0.3\%$, expressed in SI units. This reference is maintained by the World Meteorological Organization (WMO), and it has been issued since January 1, 1980
ISO9060	An ISO norm (International Standard). ISO9060 defines the pyranometer and pyrheliometer characteristics, their requirements and corresponding categories. Global pyranometers are subdivided into 3 classes in this standard.

A-2. Pyranometer Characteristics

Table A-2. Pyranometer Characteristics (see also CIMO Guide, WMO No. 8, 2008)

Response Time	The time (seconds) of a pyranometer sensor to reach 95% of its final output signal.
Zero Off-Set A	Response (dark-signal) to 200W/m net thermal radiation (ventilated)
Zero Off-Set B	Response (dark-signal) to 5K per hour change in ambient temperature
Non-Stability	Rate of change [%] of the pyranometer sensitivity per year.
Non-Linearity	Percentage deviation from the responsivity at 500W/m ² due to any change of irradiance within the range 100W/m ² to 1,000W/m ² .
Directional Response	Also referred to as cosine error [W/m ²]; the range of errors caused by assuming that the normal incidence responsivity is valid for all directions when measuring, from any direction, a beam radiation whose normal incidence irradiance is 1,000W/m ²
Spectral Sensitivity	Percentage deviation of the product of spectral absorptance and spectral transmittance from the corresponding mean within the range 0.35µm to 1.5µm.
Temperature Response	Percentage maximum error due to any change of ambient temperature within an interval of 50K.
Tilt Response	Percentage deviation from the responsivity at 0° tilt (horizontal) due to change in tilt from 0° to 90° at 1,000W/m ² .



Japan: www.eko.co.jp

Europe: www.eko-eu.com

USA: www.eko-usa.com