

CGR 4

PYRGEOMETER



IMPORTANT USER INFORMATION

Reading this entire manual is recommended for full understanding of the use of this product.

Should you have any comments on this manual we will be pleased to receive them at:

Kipp & Zonen B.V.
Delftechpark 36, 2628 XH Delft, The Netherlands
or P.O. Box 507, 2600 AM Delft, The Netherlands

T : +31 (0)15 2755210
F : +31 (0)15 2620351
E : info@kippzonen.com
W : www.kippzonen.com

Kipp & Zonen reserves the right to make changes to the specifications without prior notice.

WARRANTY AND LIABILITY



Kipp & Zonen guarantees that the product delivered has been thoroughly tested to ensure that it meets its published specifications. The warranty included in the conditions of delivery is valid only if the product has been installed and used according to the instructions supplied by Kipp & Zonen.

Kipp & Zonen shall in no event be liable for incidental or consequential damages, including without limitation, lost profits, loss of income, loss of business opportunities, loss of use and other related exposures, however used, rising from the faulty and incorrect use of the product. User made modifications can affect the validity of the CE declaration.

COPYRIGHT[©] 2006 KIPP & ZONEN

All rights are reserved. No part of this publication may be reproduced, stored in a retrieval system or transmitted in any form or by any means, without permission in written form from the company.

Manual version: 0806



Declaration of Conformity

According to EC guideline 89/336/EEC 73/23/EEC

We **Kipp & Zonen B.V.**
Delftechpark 36
2628 XH Delft
The Netherlands

Declare under our sole responsibility that the products

Type: **CGR 3 / CGR 4**

Name: **Pyrgeometer**

to which this declaration relates are in conformity with the following standards

Imissions EN 50082-1 Group standard

Emissions EN 50081-1 Group standard
 EN 55022

Safety standard IEC 1010-1

Following the provisions of the directive.

B.A.H. Dieterink
President
KIPP & ZONEN B.V.

Table of contents

IMPORTANT USER INFORMATION	1
Declaration of Conformity	2
Table of contents	3
1. Introduction	4
2. Installation and operation	5
2.1. Delivery	5
2.2. Mechanical installation	5
2.2.1. Installation for measurement of long-wave downward radiation	5
2.2.2. Installation for measurement of radiation on inclined surfaces	7
2.2.3. Installation for measurement of upward long-wave radiation	7
2.2.4. Installation for shaded measurement of downward long-wave radiation	8
2.2.5. Installation for measurement of net long-wave radiation	8
2.3. Electrical installation	9
2.4. Operation	10
2.4.1. Overcast sky	11
2.4.2. Clear sky	11
2.4.3. Measurements during a sunny day	12
2.5. Measurement uncertainty	12
2.6. Maintenance	14
3. Principle components of pyrometers	15
3.1. Window	15
3.2. Detector	16
3.3. Temperature sensor	16
3.4. Housing	17
3.5. Drying cartridge	17
3.6. Cable and connector	17
4. Pyrometer physical properties	18
4.1. Spectral range	18
4.2. Sensitivity	19
4.3. Impedance	19
4.4. Response time	19
4.5. Non-linearity	19
4.6. Temperature dependence	19
4.7. Tilt error	19
4.8. Window heating offset	20
4.9. Zero offset B due to ambient temperature changes	20
4.10. Operating temperature	21
4.11. Field of view	21
4.12. Directional response	21
4.13. Maximum irradiance	21
4.14. Non-stability	21
4.15. Spectral selectivity	21
4.16. Environmental	22
4.17. Uncertainty	22
5. Calibration	23
5.1. Calibration principle	23
5.2. Calibration procedure at Kipp & Zonen	23
5.3. Traceability to World Radiometric Reference	23
5.4. Recalibration	23
6. CGR models	24
6.1. CGR 4	24
6.2. CGR 4 performance specifications	25
6.3. CGR 4 general specifications	26
7. Frequently asked questions	27
8. Trouble shooting	28
Appendix I Radiometric terminology	29
Appendix II 10k thermistor specifications	30
Appendix III Pt-100 specifications	31
Appendix IV List of World and Regional Radiation Centres	32
Appendix V Recalibration service	33

1. Introduction

Dear customer, thank you for purchasing a Kipp & Zonen instrument. Please read this manual and the separate instruction sheet for a full understanding of the use of your pyrgeometer.

A CGR series pyrgeometer is a high quality radiometer designed for measuring long-wave irradiance on a plane surface (radiant flux, W/m^2) which results from radiation incident from the hemisphere above the instrument.

According to the World Meteorological Organisation (WMO) a pyrgeometer is the designated type of instrument for the measurement long-wave atmospheric radiation.

This manual, together with the instruction sheet, gives information related to installation, maintenance, calibration, product specifications and applications of the CGR series. Note that the smaller CGR 3 pyrgeometer with a flat infrared window is largely excluded from this manual due to the different construction. However, the general definitions and principles also apply to this model.

If any questions should remain, please feel free to contact your Kipp & Zonen dealer or e-mail info@kippzonen.com

For information about other Kipp & Zonen products or to check for any update of this manual, go to www.kippzonen.com

2. Installation and operation

2.1. Delivery

Check the contents of the shipment for completeness (see below) and note whether any damage has occurred during transport. If there is damage, a claim should be filed with the carrier immediately. In this case, or if the contents are incomplete, your dealer should be notified in order to facilitate the repair or replacement of the instrument.

Contents of delivery:

1. Radiometer
2. Sun shield
3. Cable with connector
4. Test reports
5. Instruction sheet
6. Radiometer fixing kit
7. 2 x desiccant bags
8. Product documentation CD

Although all CGR radiometers are weatherproof and suitable for harsh environmental conditions, they have some delicate mechanical parts. Please keep the original packaging for safe transport of the radiometer to the measurement site or for use when returning the radiometer for calibration.

The calibration certificate supplied with the instrument is valid for 1 year from the date of first use by the customer, subject to the variations in performance due to specific operating conditions that are given in the instrument specifications. The calibration certificate is dated relative to the time of manufacture, or recalibration, but the instrument does not undergo any sensitivity changes when kept in the original packing and not exposed to light. From the moment the instrument is taken from its packaging and exposed to irradiance the sensitivity will deviate slightly with time. See the 'non-stability' performance (maximum sensitivity change per year) given in the radiometer specification list.

2.2. Mechanical installation

The mechanical installation of the radiometer depends upon the measuring purpose. Different measuring methods will be explained in the next paragraphs.

2.2.1. Installation for measurement of long-wave downward radiation

The following steps must be carefully taken for optimal performance of the instrument.

1. Desiccant

Check the condition of the desiccant and replace if necessary, for example after a long storage period.

2. Location

Ideally the site for the pyrgeometer should be free from any obstructions to the horizon above the plane of the sensing element. If this is not possible, the site should be chosen in such a way that any obstruction over the azimuth range should have an elevation not exceeding 10° . In particular, no sources of heat (such as ventilation / heating outlets) should be within the field of view.

3. Mounting

The CGR pyrgometer is provided with two holes for 5 mm bolts. Two each of stainless steel bolts, washers, nuts and nylon insulation rings are provided in the fixing kit. The pyrgometer should first be secured lightly with the bolts to a solid and stable mounting stand or platform as shown in Figure 1. After recalibration the nylon insulators must be replaced with new ones to prevent corrosion.

The mounting stand temperature can vary over a wider range than the air temperature. Temperature fluctuations of the pyrgometer body can produce offset signals, therefore it is recommended to isolate the pyrgometer thermally from the mounting stand by placing it on its levelling screws. Ensure that there is a good electrical contact with earth to conduct away currents in the cable shield induced by lightning.

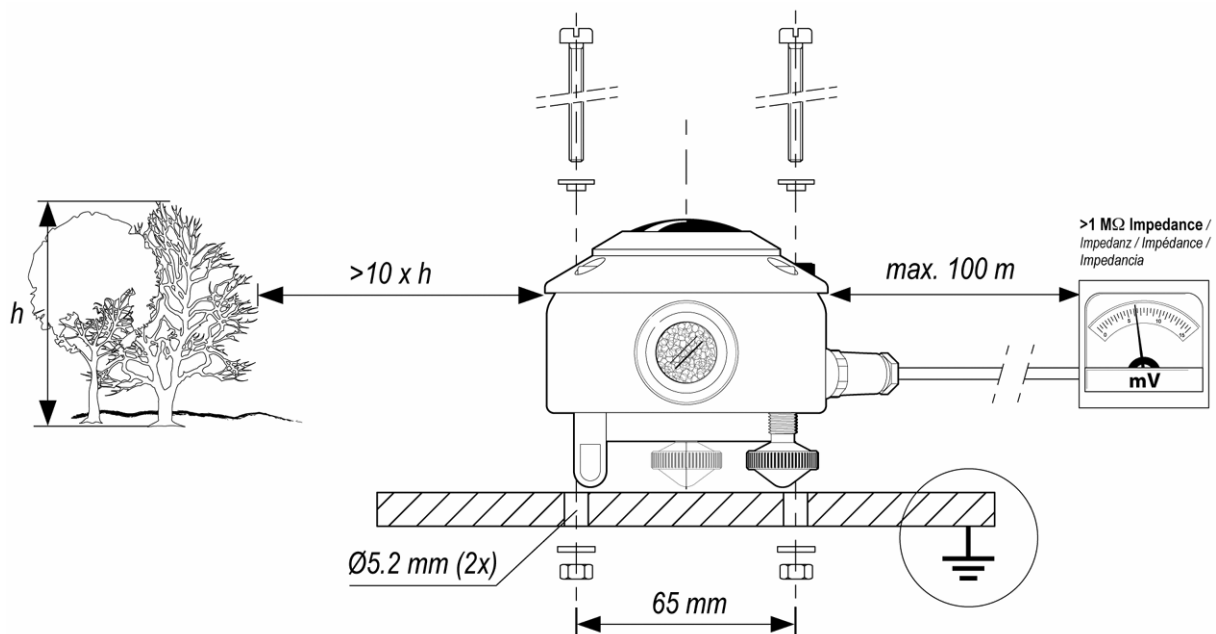

Figure 1 Pyrgometer installation

Note: After recalibration and/or reinstallation the nylon insulators must be replaced with new ones to maintain durability.

4. Orientation

In principle no special orientation of the instrument is required, although the World Meteorological Organisation (WMO) recommends that the signal lead is pointed towards the nearest pole, to minimise heating of the electrical connections.

5. Level pyranometer

Accurate measurement of the global radiation requires proper levelling of the thermopile surface. Level the instrument by turning the two levelling screws to bring the bubble of the spirit level centrally within the marked ring. For easy levelling, first use the screw nearest to the spirit level. When the pyrgometer is placed horizontally using the bubble level, or when it is mounted with its base directly on a horizontal plane, the thermopile is horizontal within 0.1° .

6. Secure pyranometer

Secure the pyregeometer tightly with the two stainless steel bolts. Ensure that the pyregeometer maintains the correct levelled position!

7. Fit cable and sun shield

Locate the cable plug correctly in the radiometer socket (it only fits one way) and screw the plug locking ring hand-tight. Finally, clip on the sun shield to prevent excessive heating of the radiometer body. The bubble level is visible through the top of the sun shield for routine checks.

2.2.2. Installation for measurement of radiation on inclined surfaces

It is advised to pre-adjust the levelling screws on a horizontal surface for easy orientation of the instrument parallel to the inclined surface. Because the temperature of the mounting stand is expected to rise considerably (more than 10°C above air temperature), the housing must be thermally isolated by the levelling screws from the stand. This will promote a thermal equilibrium between the dome and the housing and decrease zero offset signals.

2.2.3. Installation for measurement of upward long-wave radiation

In the inverted position the pyregeometer measures radiation from the ground. According to the WMO the height should be 1 m to 2 m above a uniform surface covered by short grass.

The mounting device should not interfere significantly with the field of view of the instrument. The upper plate prevents excessive heating of the pyregeometer body by solar radiation and, if large enough, it keeps the lower screen free of precipitation. The lower glare screen prevents direct illumination of the dome by the sun at sunrise and sunset and is available as an accessory kit for the CGR series.

The mast shown in Figure 2 intercepts a fraction $D/2\pi S$ of the radiation coming from the ground. In the most unfavourable situation (sun at zenith) the pyregeometer shadow decreases the signal by a factor R^2/H^2 .

A rule of thumb is:

A black shadow with radius = 0.1 H on the field below decreases the signal by 1% and 99% of the signal will originate from an area with radius 10 H.

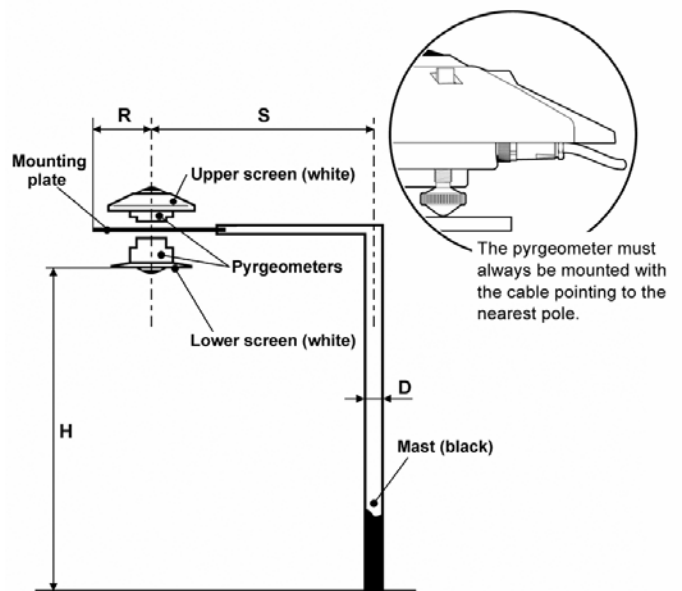

Figure 2 Upward long-wave radiation

2.2.4. Installation for shaded measurement of downward long-wave radiation

For measuring atmospheric radiation with some pyrometers, such as the CGR 3, it is desirable to shield the instrument from the direct short-wave solar radiation which may heat up the pyrometer dome or window and cause significant thermal offsets. The direct solar radiation is intercepted by a small disk or sphere. The shadow of the disk must cover the pyrometer dome completely. However, to follow the sun's apparent motion, a power-driven tracking device is necessary.

This can be done using a Kipp & Zonen sun tracker, such as the model 2AP, designed to track the sun accurately under all weather conditions. More information about the combination of pyrometer and tracker is given in the sun tracker manual.

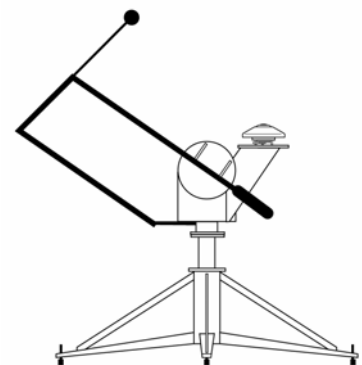

Figure 3 2AP Sun Tracker with shaded pyrometer

Alternatively, a static shadow ring can be used to intercept the direct solar radiation; but it is less accurate and may require periodic manual adjustment. At times the shadow ring also intercepts a proportion of the diffuse sky radiation. Therefore, corrections for this to the recorded data are necessary.

Kipp & Zonen produces a universal shadow ring, model CM 121, which is suitable for use at all latitudes. In the CM 121 manual, installation instructions and correction factors are given.

In practice the CGR 4 does not require shading from direct short-wave solar radiation because the dome-heating effect, when suitably ventilated, is negligible due to the unique construction of the pyrometer.

2.2.5. Installation for measurement of net long-wave radiation

A net pyrometer measures both the downward atmospheric long-wave radiation and the upward long-wave radiation from the surface below. It can be configured from two CGR series pyrometers and a suitable mounting plate. In the case of the CGR 3, two instruments can be simply mounted back-to-back and an optional mounting rod fitted.

The requirements for installation of the upper and lower pyrometers are the same as in paragraphs 2.2.1 and 2.2.3 for downward and upward long-wave radiation. A typical arrangement is shown in Figure 4. According to the WMO the height should be 1 m to 2 m above a uniform surface covered by short grass.

The mast shown intercepts a fraction $D/2\pi S$ of the radiation that is coming from the ground. In the most unfavourable situation (sun at zenith) the pyrometer shadow decreases the signal by a factor R^2/H^2 .

When determining the net long-wave radiation, it is not strictly necessary to record the pyrometer housing temperatures. Assuming that the temperatures of the upper and lower housings are equal, it can be cancelled from the equation for net-radiation.

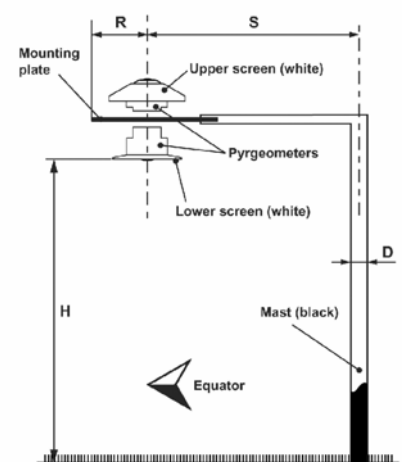

Figure 4 Net radiation configuration

However, if the upward and downward radiation components are to be measured separately it is necessary to record the individual housing temperatures to calculate the radiation values.

Using the combination of a net pyrgometer (two CGR 3 or CGR 4 instruments) and a CMA 6 or CMA 11 albedometer the net total radiation (energy balance) can be calculated with high accuracy from the four component values. Problems with dew deposition, frost, etc, can be minimised by using the Kipp & Zonen CV 2 ventilation unit with optional heating.

This has many advantages over conventional net total radiation sensors with plastic (polyethylene) windows. These cannot provide individual short and long-wave radiation values and cannot separate upward and downward contributions. The soft plastic domes do not fully protect the sensor from the thermal effects of wind and rain, are easily soiled, are difficult to clean and require regular replacement.

2.3. Electrical installation

As standard the CGR is supplied with a waterproof connector pre-wired to 10 m cable with a number of leads and a shield covered with a black sleeve. The number of connector pins and cable leads depends upon the type of temperature sensor that is fitted. The colour code of the wires and the connector pin numbers are shown on the instruction sheet. Longer cables are available as options.

Preferably, secure the pyrgometer with its levelling screws or mounting rod to a metal support with a good connection to earth (e.g. by using a lightning conductor).

The shield of the cable is connected to the aluminium radiometer housing through the connector body. The shield at the cable end may be connected to ground at the readout equipment. Lightning can induce high voltages in the shield but these will be led off at the pyranometer and data logger.

Kipp & Zonen pyrgometer cables are of low noise type, but bending the cable produces small voltage spikes, a tribo-electric and capacitance effect. Therefore, the cable must be firmly secured to minimise spurious responses during stormy weather.

The impedance of the readout equipment loads the temperature compensation circuit and the thermopile. It can increase the temperature dependency of the pyrgometer. The sensitivity is affected more than 0.1% when the load resistance is less than 100 k Ω . For this reason we recommend the use of readout equipment with an input impedance of 1 M Ω or more. The solar integrators, data loggers and chart recorders from Kipp & Zonen meet these requirements.

Long cables may be used, but the cable resistance must be smaller than 0.1% of the impedance of the readout equipment. It is evident that the use of attenuator circuits to modify the calibration factor is not recommended because the temperature response will also be affected.

A high input bias current at the readout equipment can produce several micro-Volts across the impedance of the pyrgometer and cable. The zero offset can be verified by replacing the pyrgometer impedance at the readout equipment input terminals with a resistor.

The pyrgometer can also be connected to a computer or data acquisition system. A low voltage analogue input must be available. The resolution of the Analogue-to-Digital Converter (ADC) must allow a system sensitivity of about 1 bit per W/m². More resolution is not necessary during outdoor measurements, because even the best pyrgometer (the CGR 4) exhibits offsets greater than 2 W/m² due to lack of thermal equilibrium.

For amplification of the pyrgometer signal Kipp & Zonen offers the AMPBOX signal amplifier. This amplifier will convert the micro-Volt output from the pyranometer into a standard 4 – 20 mA signal. The use of the AMPBOX amplifier is recommended for applications with long cables (> 100 m), electrically noisy environments or data loggers with a current-loop input. The AMPBOX can be factory adjusted to suit the sensitivity of an individual pyrgometer to produce a defined range, typically 4 mA represents -300 W/m², 16 mA represents 0 W/m² and 20 mA represents +100 W/m².

2.4. Operation

After completing the installation the pyrgometer will be ready for operation.

The downward atmospheric long-wave radiation can be calculated with Formula 1 by measuring the detector output voltage U_{emf} [μ V], the housing temperature T_b [K], and taking the sensitivity calibration factor S [μ V/W/m²] into account.

$$L_d = \frac{U_{emf}}{S} + 5.67 \cdot 10^{-8} \cdot T_b^4 \quad \text{Formula 1}$$

L_d = Downward atmospheric long-wave radiation [W/m²]

$\frac{U_{emf}}{S}$ = Net radiation (difference between the downward long-wave radiation emitted from the atmosphere and the upward irradiance of the CGR 4 detector) [W/m²]

$5.67 \cdot 10^{-8} \cdot T_b^4$ = Upward irradiance of the CGR 4 detector [W/m²]

Note that the net radiation term (U_{emf} / S) is mostly negative, so the calculated downward atmospheric long-wave radiation is smaller than the detector's upward irradiance ($5.67 \cdot 10^{-8} \cdot T_b^4$).

This refers to the net radiation within the pyrgometer, not the 'net radiation' as referred to in 2.2.5.

In the Baseline Surface Radiation Network (BSRN) manual (WMO/TD-No.897) an extended formula is described. This formula corrects for window heating and so called "solar radiation leakage". Due to the very low window heating offset and optimal spectral cut-on wavelength, these corrections are not necessary for the CGR 4.

To be certain that the quality of the data is of a high standard, care must be taken with daily maintenance of the pyrgometer. Once a voltage measurement is taken, nothing can be done to retrospectively improve the quality of that measurement.

During field measurements the pyrgometer is exposed to varying atmospheric conditions with typical radiating properties. Therefore we define the two most common conditions as 'overcast sky' and 'clear sky', refer to 2.4.1 and 2.4.2 respectively.

2.4.1. Overcast sky

Typical for a cloudy overcast sky is that radiation emitted by the earth is absorbed 100% by the clouds. Therefore, the overcast sky will re-emit the radiation (L_d) 100%.

In theory, the net radiation (U_{emf} / S) will be zero, so the pyrgeometer detector output voltage (U_{emf}) will be zero. In practice, the detector output shows a small negative voltage (a few W/m^2), due to a small heat exchange between the relatively warm pyrgeometer and the colder sky.

In this case the calculated atmospheric long-wave radiation (L_d) shows a relatively large positive value. In the case of rain, the detector output will read zero, because water deposited on the pyrgeometer window is a perfect infrared absorber. A cloudy overcast sky condition is illustrated in Figure 5.

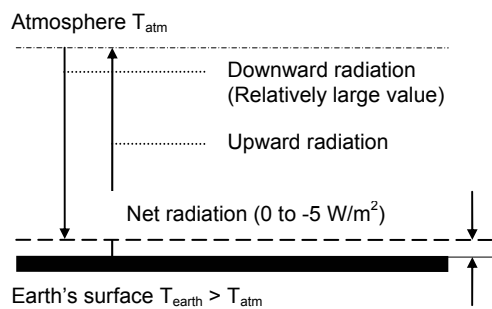

Figure 5 Cloudy overcast sky condition

2.4.2. Clear sky

Clear sky conditions differ in that there is a relatively large heat loss caused by the atmospheric window. The amount of re-emitted radiation by a clear sky is smaller compared to the overcast sky condition.

Because of the heat loss in the upward direction, the thermopile hot junctions will cool down and show a relatively large negative net radiation value (from -90 to $-130 W/m^2$). Therefore, the calculated atmospheric long-wave radiation (L_d) shows a relative small positive value. A clear sky condition is illustrated in Figure 6.

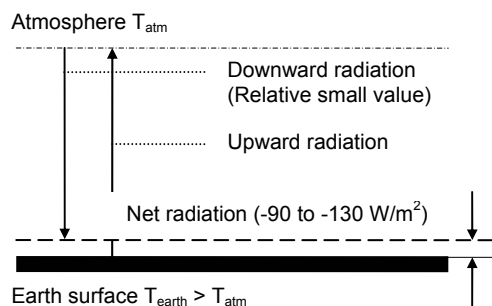

Figure 6 Clear sky condition

2.4.3. Measurements during a sunny day

The CGR 4 differs from all other pyrgometers in that it allows accurate daytime measurements on sunny days without the need for a shading device. Due to the unique construction of the CGR 4, solar radiation of up to 1000 W/m^2 induces window heating of less than 4 W/m^2 in the overall calculated downward radiation.

Formula 1 can be applied without any problems with the following exception; one must take note of the amount of Infrared radiation in the solar spectrum. The amount of solar infrared radiation depends on many parameters; for example the water vapour content in the atmosphere (humidity), location of the CGR 4 at a certain altitude and the sun's declination angle. Figure 7 indicates the possible infrared radiation in the solar spectrum in the case of low water content in the atmosphere. The amount of solar infrared detected at the CGR 4 (and the CGR 3) is expected to be very low (0 to 3 W/m^2) because of the filter cut-on at $4.5 \mu\text{m}$. Other types of pyrgometers can exhibit 0 – 10 W/m^2 .

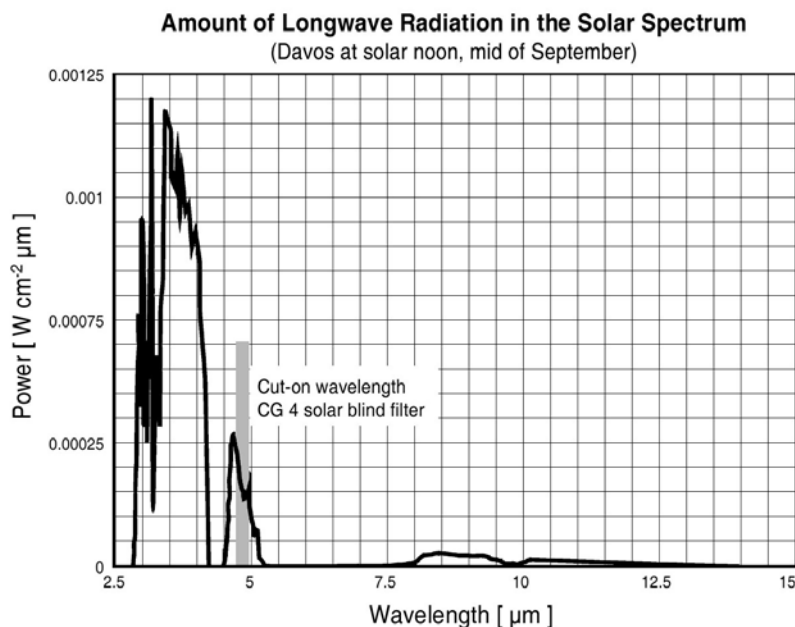

Figure 7 Direct solar irradiance in Davos, Switzerland at solar noon in mid-September

2.5. Measurement uncertainty

When a pyrgometer is in operation, the performance of it is correlated to a number of parameters, such as temperature, level of irradiance, angle of incidence, etc. Normally, the supplied sensitivity figure is used to calculate the irradiances. If the conditions differ significantly from calibration conditions, uncertainty in the calculated irradiances must be expected.

Kipp & Zonen expects maximum uncertainty of 2% for hourly totals and 1% for daily totals for the CGR 4 pyrgometer. This remaining uncertainty can be reduced further if the sensitivity of the pyrgometer under the prevailing conditions is used, with corrections calculated from the effects of parameters such as temperature and non-linearity. This is especially convenient with a programmable data acquisition system.

For the CGR 4 the effect of each parameter on the sensitivity can be shown separately. The non-linearity error, the sensitivity variation with irradiance, is the same for any CGR 4 and is shown in Figure 8.

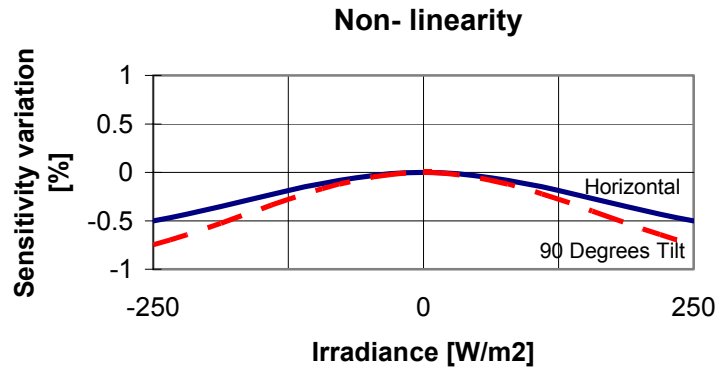

Figure 8 Non-linear sensitivity variation with irradiance of a CGR 4 pyrgometer

The temperature dependence of the sensitivity is a function of the individual CGR 4. For a given CGR 4 the response lies in the region between the curved lines in Figure 9. The temperature dependence of each CGR 4 pyrgometer is characterised and supplied with the instrument. Each CGR 4 has a built-in temperature sensor to allow corrections to be applied if required.

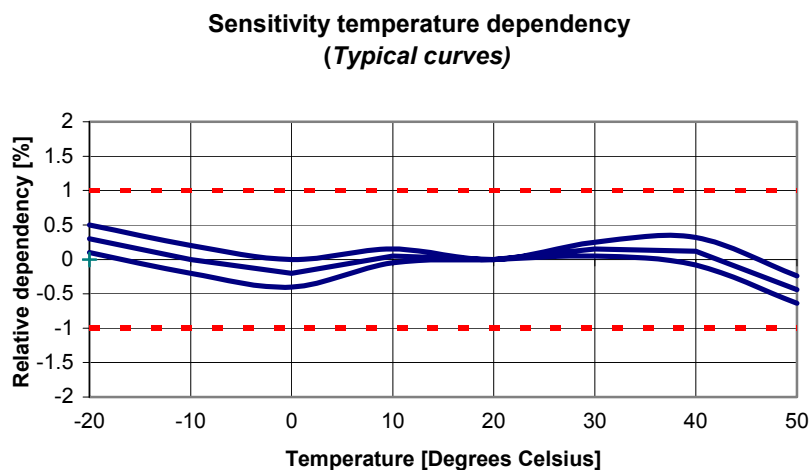

Figure 9 Typical temperature dependency of a CGR 4

2.6. Maintenance

Once installed the pyrgeometer needs little maintenance. The dome / window must be cleaned and inspected regularly, ideally every morning. On clear windless nights the dome / window temperature of horizontally placed pyrgeometers will decrease, even to the dew point temperature of the air, due to infrared radiation exchange with the cold sky. (The effective sky temperature can be 30°C lower than the ground temperature). In this case dew, glazed frost or hoar frost can be precipitated on the top of the outer dome and can stay there for several hours in the morning. An ice cap on the dome is a strong diffuser and increases the pyranometer signal drastically, up to 100% in the first hours after sunrise. Hoar frost disappears due to solar radiation during the morning, but should be wiped off as soon as possible manually.

The dome of the pyrgeometer can be ventilated continuously by a heated blower to keep the dome / window above the dew point temperature. The need for heating strongly depends upon local climatological circumstances. Generally, heating is advised during cold seasons when frost and dew can be expected. The Kipp & Zonen CV 2 ventilation unit is specially designed for unattended operation under most weather conditions and has a choice of heating levels.

Note that the CGR 3 pyrgeometer cannot be used with the CV 2 ventilation unit

A periodic check is to ensure that the pyrgeometer is level and that the silica gel desiccant is still coloured orange. When the orange silica gel in the drying cartridge is turned completely transparent (normally after several months), it must be replaced by fresh silica gel as supplied in the small refill packs. The content of one pack is sufficient for one complete refill. At the same time check that the pyrgeometer mounting is secure and that the cable is in good condition.

Some tips when changing the desiccant:

- Make sure the surfaces of the pyrgeometer and the drying cartridge that touch the rubber o-ring are clean (corrosion can do a lot of harm here and dirt, in combination with water, can cause this);
- The rubber o-ring is coated with a silicon grease to improve the seal. If the rubber o-ring looks dry apply some grease to it (Vaseline will also do);
- Check that the drying cartridge is tightly threaded into the pyrgeometer body.

It is very difficult to make the pyrgeometers hermetically sealed; so, due to pressure differences between the inside and the outside of the instrument, there will always be some exchange of (humid) air.

The pyrgeometer sensitivity changes with time and with exposure to radiation. Calibration every two years is advised. Further information about Kipp & Zonen recalibration services can be found in Appendix V.

3. Principle components of pyrometers

The detector of the Kipp & Zonen CGR series pyrometer is based on a passive thermal sensing element called a thermopile. Although the detector construction differs from model to model, the fundamental working principle is applicable to all CGR series radiometers.

The thermopile responds to the total power absorbed by the black surface coating, which is a non-spectrally selective paint, and warm up. The heat generated flows through a thermal resistance to the heat-sink (the pyrometer body). The temperature difference across the thermal resistance of the detector is converted into a voltage as a linear function of the absorbed solar irradiance.

The rise of temperature is easily affected by wind, rain and thermal radiation losses to the environment ('cold' sky). Therefore the CGR 4 detector is shielded by a silicon meniscus dome (the entry-level CGR 3 has a flat silicon window to reduce cost). A drying cartridge (desiccator) in the radiometer housing is filled with silica gel and prevents dew on the inner sides of the domes, which can cool down considerably on clear windless nights.

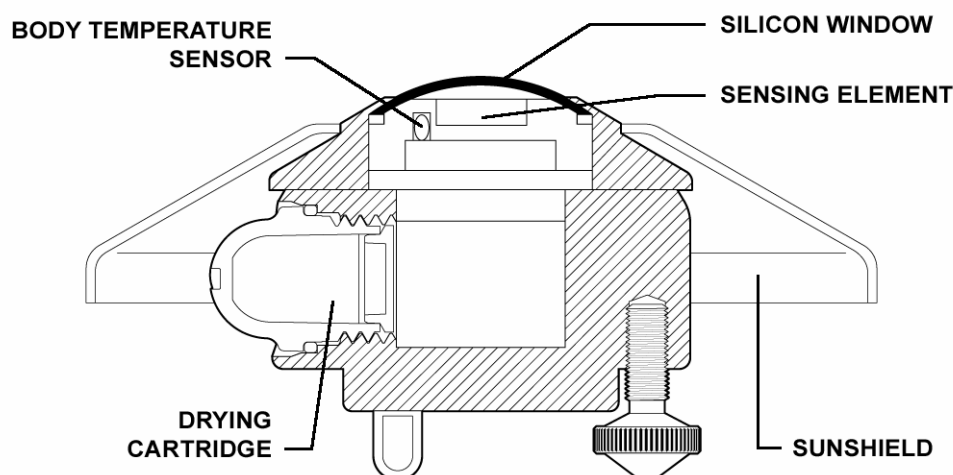

Figure 10 Construction details of CGR 4 pyrometer

3.1. Window

The inner surface of the silicon dome / window has an interference filter deposited on it for transmitting the long-wave radiation and blocking the short-wave solar radiation from reaching the detector. The silicon window material and the deposited 'solar blind' filter defines the spectral measurement range of the pyrometer.

The silicon window allows transmittance of the atmospheric long-wave radiation up to approximately 42 μm and about 50 - 60% of the radiation spectrum will be transmitted through to the detector. The outer surface of the CGR 4 dome has a hard-carbon, diamond-like layer, deposited as additional protection against environmental influences in harsh environments and to smooth out the window transmission beyond 30 μm .

The solar blind filter is opaque to radiation below 4.5 μm , known as the cut-on wavelength. Currently most pyrgeometers have their cut-on at a lower wavelength. Problems may occur in the case of clear sunny days with low humidity. In the solar spectrum between 2.5 and 4.5 μm there can still be an amount of infrared solar radiation up to 10 W/m^2 , which should not be included in the measurement. This unwanted fraction is blocked in the CGR 4 by the filter coating.

CGR 4 uses a specially designed pure silicon dome. Although the dome is not hemispherical, CGR 4 has a 180° field of view with good cosine response. A big advantage of the meniscus shaped dome over the typical hemispherical dome is the ability to deposit more uniform coatings on the window surface. Deposition of a uniform filter coating on a strongly curved surface is very difficult and unpredictable process. To avoid these problems Kipp & Zonen developed a dome with excellent optical quality due to the optimised shape and coating uniformity.

The solar radiation absorbed by the window is conducted away very effectively by a unique construction in the CGR 4. Even in full sunlight the window heating effect is very low compared to that of other pyrgeometers on the market. This allows accurate daytime measurements without the need for a shading disk. It also eliminates the need for window heating compensation by using the correction formula and window temperature sensors.

3.2. Detector

The thermopile sensing element is made up of a large number of thermocouple junction pairs connected electrically in series. The absorption of thermal radiation by one of the thermocouple junctions, called the active (or 'hot') junction, increases its temperature. The differential temperature between the active junction and a reference ('cold') junction kept at a fixed temperature produces an electromotive force directly proportional to the differential temperature created. This is a thermoelectric effect. The sensitivity of a pyranometer depends on the individual physical properties of the thermopile and construction. The sensitivity of each thermopile is unique and therefore each radiometer has unique calibration factor, even with the same radiometer model.

On the top surface of the sensor a black paint is deposited which has a very rough structure containing many micro-cavities that effectively "trap" more than 95% of the incident radiation in a broad spectral range. Furthermore, the spectral selectivity is less than 3%. This means that within the spectral range of the pyrgeometer, the absorption for each wavelength is equal to within 3%. The black painted sensing element forms the detector. Considering the long-term stability of the instrument, the black paint is one of the most crucial and delicate parts of the pyrgeometer. Kipp & Zonen black paint gives the best possible stability over a long period of time under all meteorological circumstances.

3.3. Temperature sensor

The housing temperature sensor is a crucial part of a pyrgeometer and is needed to calculate the downward long-wave radiation component. The body temperature sensor represents the 'absolute' temperature of the detector surface and therefore it is mounted close to the cold junctions of the detector. A housing temperature sensor is fitted as standard to the CGR pyrgeometers.

3.4. Housing

The radiometer housing accommodates all fundamental pygeometer parts. The anodized Aluminium parts are light weight and give a high mechanical and thermal stability to the instrument. Due to its fine mechanical construction all pygeometers are virtually sealed and comply to the international standard IP 67. Each pygeometer model can be leveled by using the bubble level and two leveling feet. For ease of maintenance the bubble level is situated next to the dome of the instrument and due to the special shape of the sun shield it is visible from above. The sun shield acts to protect all the external parts from radiation and to reduce solar heating of the housing.

3.5. Drying cartridge

In case moisture enters the radiometer body the silica-gel desiccant regulates the humidity level inside the pyranometer. Initially the desiccant will have an orange colour. After some time it becomes saturated with moisture and the colour will change to become clear (transparent). At this time the contents of the drying cartridge should be replaced with fresh, unsaturated orange colored desiccant as soon as possible. Replacement desiccant is available through Kipp & Zonen distributors.

3.6. Cable and connector

For ease of installation and replacement during recalibration of the radiometer, the CGR series are provided with a weather proof signal cable connector.

Kipp & Zonen radiometers use a custom-made cable that is selected as a low noise type particularly suited to handle the low voltage output of the thermopile or of a temperature sensor.

The shield of the cable is connected to the metal body of the connector and preferably should be connected to ground at the readout equipment. Cables come pre-wired to the connector plug in a range of lengths.

4. Pyrgeometer physical properties

4.1. Spectral range

The spectral properties of the pyrgeometer are mainly determined by the filter characteristics of the silicon window and the coatings. The application is primarily to measure long-wave downward atmospheric radiation. The spectral range is from 4.5 to 42 μm , where most of this radiation is present.

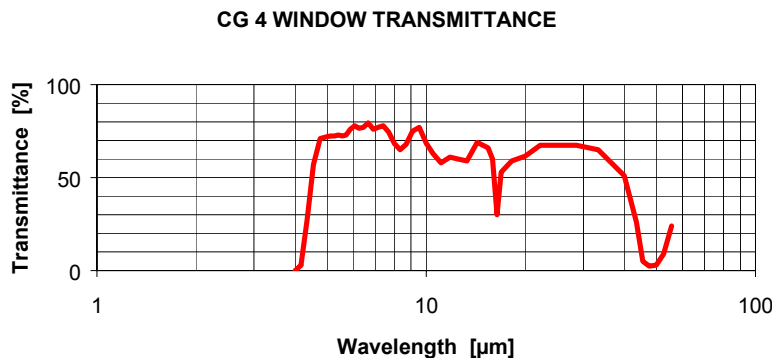

Figure 11 Pyrgeometer spectral window properties

The atmosphere is transparent to long-wave radiation emitted by the Earth's surface in certain wavelength intervals, particularly within a spectral range of approximately 8 to 14 μm . This is called the 'atmospheric window'. Within this spectral range the Earth is able to maintain an equilibrium temperature by losing a certain quantity of heat gained each day from the sun.

The sun radiates approximately as a blackbody at an equivalent temperature of 5770K. Almost 99% of its emitted energy is contained in wavelengths less than 4 μm , called short-wave radiation. The equivalent radiant temperature of the Earth's surface is about 275K. More than 99% of this energy is emitted at wavelengths greater than 3 μm and is called long-wave, thermal, or infrared, radiation.

Downward long-wave radiation is a result of atmospheric re-emission. Re-emission is the reversible effect of absorption of long-wave radiation emitted by the Earth and by chemical elements such as water (H_2O), Oxygen (O_2), Ozone (O_3), Carbon dioxide (CO_2), etc. These elements are the main emitters of long-wave radiation in the atmosphere. The remaining unabsorbed portion of the Earth's radiation escapes into outer space. Under clear skies an object can be cooled below ambient air temperature by radiative heat loss to the sky.

Observing the earth from outer space, a blackbody is seen in a range of 8 to 14 μm with a temperature of 14 $^\circ\text{C}$ and outside this wavelength range a blackbody of -60°C . Under clear sky conditions in a reverse direction, outer space can be observed in the same spectral range.

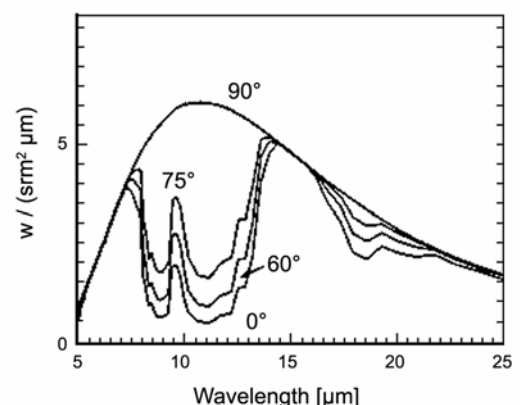

Figure 12 Atmospheric radiation

4.2. Sensitivity

The radiometer thermopile sensitivity is mainly determined by the physical properties of the detector itself. The thermoelectric power, thermal conductivity of the junctions and the overall dimensions of the sensing element are related to its sensitivity.

4.3. Impedance

The radiometer impedance is defined as the total electrical impedance at the radiometer output connector fitted to the housing. It arises from the electrical resistance in the thermal junctions, wires and passive electronics within the radiometer.

4.4. Response time

Any measuring device requires a certain time to react to a change in the parameter being measured. The radiometer requires time to respond to change in the incident radiation. The response time is normally quoted as the time for the output to reach 95% (sometimes 63%) of the final value following a step-change in irradiance. It is determined by the physical properties of the thermopile and the radiometer construction. CGR series pyrgeometers have a fast response, which makes them suitable for measuring far infrared radiation (FIR) under variable weather conditions.

4.5. Non-linearity

The non-linearity of a pyrgeometer is the percentage deviation in the sensitivity over a net irradiance range from -250 to $+250$ W/m^2 compared to the sensitivity calibration irradiance of -100 W/m^2 . The non-linearity effect is due to convective and radiative heat losses at the black absorber surface which make the conditional thermal equilibrium of the radiometer non-linear.

4.6. Temperature dependence

The sensitivity change of the pyrgeometer with ambient temperature change is related to the thermodynamics of the radiometer construction. The temperature dependence is given as percent deviation with respect to the calibrated sensitivity at $+20^\circ\text{C}$. The CGR 4 has passive electrical compensation circuits to minimise this effect. Each CGR 4 pyrgeometer is supplied with an individual test certificate stating the temperature dependency in the range from -20°C to $+50^\circ\text{C}$, at 10°C intervals. The CGR series pyrgeometers are fitted as standard with an internal temperature sensor to allow sensitivity corrections to be applied if desired.

4.7. Tilt error

This is the deviation from the sensitivity at 0° tilt (exactly horizontal) over the range from 0° to 90° tilt. The tilt response is proportional to the incident radiation. The error could be corrected for, in applications where it is necessary to install the pyranometer on an inclined surface, but is usually insignificant.

4.8. Window heating offset

Currently the major source of error concerning common pyrgeometer measurements is caused by the so-called 'window heating offset'. When a pyrgeometer is exposed to the sun, heating of the silicon dome / window occurs due to absorption of solar radiation by the material. As a consequence the dome / window of most types of pyrgeometer will heat up proportionally to the solar irradiance.

The resulting temperature difference between dome / window and thermopile will cause heat transfer by radiation and convection to the sensor. This affects the net thermal radiation as measured by the thermopile and is commonly referred to as the 'window heating offset'. The result is measurement of a too high value for downward long-wave radiation.

This offset is not easily reduced by ventilation, which only cools off $50 \text{ W/m}^2/\text{°C}$ at maximum while solar radiation can be absorbed at a rate of about 500 W/m^2 on a sunny day. Currently certain types of pyrgeometers are equipped with one or more thermistors to measure the dome / window absolute temperature that represents the apparent offset. A complex calculation must be performed to eliminate the offset.

Arguments against a thermistor to measure window temperature are:

- The thermistor contacts a part of the dome / window, it is a blackbody radiator and heat source itself and its material and adhesive increases the mean emission coefficient of the inner dome / window surface. Its presence increases the window-heating offset.
- Under clear skies the direct solar irradiance impacts mainly from one direction, so for a hemispherical dome it is recommended to have 3 equally-spaced thermistors to determine the mean dome temperature.
- The dome / window thermistor(s) should be carefully matched with the housing thermistor because calculations must be done using the temperature difference of the two thermistors.
- The customer needs between one and three extra data logger channels for the dome / window thermistor inputs.

Because of the possible problems caused by dome / window thermistors Kipp & Zonen developed the revolutionary CGR 4 pyrgeometer. In the CGR 4, dome heating is strongly suppressed by a unique construction that very effectively conducts the absorbed heat away into the housing. CGR 4 temperature variations between dome and detector are less than 0.3 degrees Celsius, compared with up to 3°C for other types of pyrgeometers. In CGR 4 the window heating offset is less than 4 W/m^2 . This allows accurate daytime measurements, even in full sunlight, without the need for a tracking shading disk.

4.9. Zero offset B due to ambient temperature changes

Proportionally to the ambient temperature the instrument temperature varies and causes heat currents inside the instrument. This will cause an offset commonly called Zero Offset type B. It is quantified as the response in W/m^2 to a 5 K/hr change in ambient temperature.

4.10. Operating temperature

The operating temperature range of the radiometer is determined by the physical properties of the individual parts. Within the specified temperature range Kipp & Zonen radiometers can be operated safely. Outside this temperature range special precautions should be taken to prevent any physical damage or performance loss of the radiometer. Please contact your distributor for further information regarding operation in unusually harsh temperature conditions.

4.11. Field of view

The field of view is defined as the unobstructed open viewing angle of the radiometer. WMO requires that a high quality pyrgeometer for the measurement of long-wave atmospheric radiation has a field of view of 180° in all directions (i.e. a hemisphere). CGR 4 achieves this. The inherent field of view of the instrument should not be confused with the clear field of view of the installation location.

For less critical applications pyrgeometers having a flat silicon window with a typical field of view of 150° are acceptable, such as the CGR 3.

4.12. Directional response

Radiation incident on a flat horizontal surface originating from a point source with a defined zenith position will have an intensity value proportional to the cosine of the zenith angle of incidence. This is sometimes called the 'cosine-law' or 'cosine-response' and is very important in the measurement of short-wave solar radiation. However, the directional response of pyrgeometers is largely irrelevant since the hemisphere above does not act like a point source.

4.13. Maximum irradiance

The maximum irradiance is defined as the total irradiance level beyond which physical damage may occur to the instrument.

4.14. Non-stability

This is the percentage change in sensitivity over a period of one year. This effect is mostly due to degradation by UV radiation of the black absorber paint on the sensing element surface. Kipp & Zonen recommends recalibration every two years. However, for quality assurance purposes some institutes, companies or networks may require more or less frequent recalibration. Please read the chapter on the calibration procedure for pyranometers for more information.

4.15. Spectral selectivity

Spectral selectivity is the variation of the dome transmittance and absorption coefficient of the black detector paint with wavelength and is commonly specified as % of the mean value.

4.16. Environmental

The CGR series are intended for outdoor use under all expected weather conditions. The radiometers comply with IP 67 and their solid mechanical construction is suitable to be used under all environmental conditions within the specified ranges.

4.17. Uncertainty

The measurement uncertainty can be described as the maximum expected hourly or daily uncertainty with respect to the 'absolute truth'. The confidence level is 95%, which means that 95% of the data-points lie within the given uncertainty interval representing the absolute value. Kipp & Zonen empirically determine uncertainty figures based on many years of field measurements.

5. Calibration

5.1. Calibration principle

An ideal radiometer gives voltage output that is proportional to the absolute irradiance level. This relationship can be expressed as a constant ratio called 'sensitivity' ($S_{\text{sensitivity}}$).

The sensitivity figure of a particular pyrgeometer is unique. In the case of the CGR 4 it is determined outdoors by comparison against a reference CGR 4 pyrgeometer. The reference pyrgeometer is calibrated outdoors regularly at the World Radiation Centre (WRC) at Davos, Switzerland.

5.2. Calibration procedure at Kipp & Zonen

CGR 4 pyrgeometers are calibrated outdoors at Kipp & Zonen under a mainly clear sky during night-time. The test instruments are installed next to the reference CGR 4. The pyrgeometer detector outputs (U_{emf}) and housing temperatures (T_b) are measured each second and compressed to one minute averages. Afterwards the downward radiation (L_d) on the reference pyrgeometer is calculated using Formula 2:

$$L_d = \frac{U_{\text{emf}}}{S} + 5.67 \cdot 10^{-8} \cdot T_b^4 \quad \text{Formula 2}$$

For the test CGR 4's a one minute average sensitivity is calculated using the Formula 3:

$$S_t = U_t / (L_d - 5.67 \cdot 10^{-8} \cdot T_b^4) \quad \text{Formula 3}$$

A final S_t is determined using only one minute S_t 's determined under clear sky conditions when;

Net IR-exchange = $L_d - 5.67 \cdot 10^{-8} \cdot T_b^4 > 40 \text{ W/m}^2$.

The sum of all periods must be at least 6 hours for a successful calibration.

5.3. Traceability to World Radiometric Reference

Reference radiometers, which are calibrated annually by the World Radiation Centre in Davos, are used for the calibration of radiometers manufactured by Kipp & Zonen. The reference radiometers are fully characterized, i.e. linearity, temperature dependence and directional response are recorded.

Kipp & Zonen keeps two reference radiometers for each radiometer model. These reference radiometers are sent alternate years to WRC for calibration, so production and calibration in Delft can carry on without interruption.

5.4. Recalibration

Radiometer sensitivity changes with time and with exposure to radiation. Periodic calibration every two years is advised. Accurate calibrations can be done outdoors under clear sky conditions by comparison to a reference pyrgeometer of equal or higher standard.

6. CGR models

The CGR series comprises 2 models, CGR 3 and CGR 4. The mechanical construction of the CGR 3 differs from the CGR 4 in that it has a flat silicon window, smaller housing dimensions and no drying cartridge (the housing is completely sealed). Features and specifications of the CGR 4 pyrgeometers are given in this chapter. The CGR series is designed for measuring the downward radiation (W/m^2) on a plane surface from the atmosphere above.

CGR 4 pyrgeometer includes an integrated bubble level, refillable drying cartridge, white snap-on sun shield, and a shielded signal output cable with connector.

CGR 4 can be used in conjunction with the Kipp & Zonen CV 2 ventilation unit for enhanced measurement performance and overall reduced instrument maintenance.

For reducing the window heating offset error, the direct solar radiation can be shielded statically from the CGR 3 pyrgeometer by the Kipp & Zonen shadow ring CM 121, and fully automatically by the 2 AP sun tracker with shading system. This can also be done for the CGR 4 but is not really necessary because of the minimal window heating effect.

A net pyrgeometer measures both the downward atmospheric long-wave radiation and the upward long-wave radiation from the surface below. It can be configured from two CGR 4 series pyrgeometers and a suitable mounting plate. In the case of the CGR 3, two instruments can be simply mounted back-to-back and an optional mounting rod fitted.

6.1. CGR 4

CGR 4 has been designed for scientific measurements outdoors of downward atmospheric long-wave radiation with extremely high reliability and accuracy.

CGR 4 provides an output voltage that is proportional to the net radiation in the far infrared (FIR). By calculation, downward atmospheric long-wave radiation is derived. CGR 4 has an integrated temperature sensor to measure the housing temperature.

CGR 4 uses a specially designed silicon meniscus dome. Although the window is not hemispherical, CGR 4 has a 180° field of view with good cosine response. A hard-carbon, diamond-like, coating protects the outer surface of the window and smoothes the spectral response. On the inside, a solar blind interference filter blocks all short-wave solar radiation.

The solar radiation absorbed by the window is conducted away into the housing very effectively, by a unique construction. Even in full sunlight the window heating offset is very low compared to that of other pyrgeometers on the market. This allows accurate daytime measurements without the need for a tracking shading disk. It also eliminates the need for window heating compensation by using the correction formula.

The special features of the CGR 4 are:

- Sensitive to infrared radiation in a wavelength range from 4.5 to 42 μm .
- Extremely low window heating offset.
- 180 ° field of view with good cosine response.
- Diamond-like coating for optimal protection against environmental influences.
- Low temperature dependence of sensitivity.

6.2. CGR 4 performance specifications

Specification	Unit	Value	Remark
Spectral range	μm	4.5 to 42	50% point
Sensitivity	$\mu\text{V}/\text{Wm}^{-2}$	5 to 10	
Impedance	Ohm	40 to 200	
Response time	s	< 18	95% response
		< 6	63% response
Non-linearity	%	< 1	from -250 to +250 W/m^2 irradiance
Temperature dependence of sensitivity	%	< 5	- 40 °C to -20 °C
		< 1	- 20 °C to +50 °C
		< 10	+50 °C to +80 °C
Tilt error	%	< 1	deviation when facing downwards
Window heating offset	W/m^2	< 4	0 to 1000 W/m^2 / solar irradiance
Zero offset B	W/m^2	< 2	at 5 K/h temp. change
Operating temperature:	°C	-40 to +80	
Field of view:		180°	
Directional error	W/m^2	Not defined	Irrelevant to isotropic IR source
Irradiance:	W/m^2	-250 to +250	
Non-stability	%	< 1	
Spectral selectivity	%	< 5	8 – 14 μm spectral range
Environmental		humidity 0 - 100% RH	
Uncertainty in hourly total	%	Not defined	95 % confidence level
Uncertainty in daily total		< 3	95 % confidence level

6.3. CGR 4 general specifications

Construction	Unit	Specification
Sensor		Thermopile (64 thermal junctions)
Receiver paint		Carbon Black
Dome (meniscus)		Silicon
Dome coating		Hard Carbon (Outside), Solar blind Interference (Inside)
Temperature sensor		1. Thermistor (standard): YSI 44031 10k@25°C Thermistor. $\pm 0.2^{\circ}\text{C}$ 2. Pt-100 (optional) DIN IEC 751. Class A
Desiccant		Silica gel
Housing materials		Anodized Aluminium body
Cable Connector materials		Shell : CuZn (self extinguishing)
		Contacts : CuZn (nickel, gold plated)
		Locking nut : CuZn (brass, nickel plated)
Chassis connector		Shell : CuZn (Brass, Nickel plated) Contacts : CuZn (Nickel , gold plated)
Cable		Color Yellow (RAL 1021), Poly Urethane, Halogen free, UV blocking
Cable length	m	10 (standard), 25, 50 (optional)
Bubble level sensitivity		0.1° (bubble inside ring)
Cable wires (pin)		(1) Red (+) signal
		(2) Blue (-) signal
		(3) Green (HI) (Pt-100)(10K therm)
		(4) Yellow (LO) (Pt-100)(10K therm)
		(5) Gray (HI) (Pt-100)
		(6) Brown (LO) (Pt-100)
Total weight	kg	0.6 without cable
		0.9 with 10 m cable
Outer dimensions	mm	79 x 77 (WxH), sunscreen \varnothing 150
Sensor height	mm	72.5
International standards		
WMO		N/A
ISO		N/A
Shock / vibration		IEC 721-3-2-2m2
CE		according to EC guideline 89/336/EEC 73/23/EEC
Environmental protection		IP 67
Instrument calibration		
		Outdoors, side by side against reference CG 4
Measurement certificates		
		Calibration certificate
		TC measurement report

7. Frequently asked questions

The most frequently asked questions are listed below. For an update refer to the Kipp & Zonen website at www.kippzonen.com

- What are typical values for downward atmospheric long wave radiation?

Ambient temperature	Overcast sky ($L_{net} = 0 \text{ W/m}^2$)	Clear sky ($L_{net} = -150 \text{ W/m}^2$)
	L_d in W/m^2	
-20 °C	230	80
0 °C	315	165
+30 °C	480	330

- The values calculated with the formula given in chapter 2 show a very strange value. What could be the reason?
- Check whether the (instrument) temperature (T_b) is given in Kelvin.
 - Check that the net radiation (U_{emf} / S) is a negative value, if not, the signal wires are possibly interchanged.
- Is the pyrgeometer sensitivity affected by the length of the signal cable?

With longer cable lengths the impedance increases, however it does not affect the radiometer sensitivity for the following reason. The impedance of the voltage measurement device is at least 10000 times more than the impedance of the pyrgeometer plus cable. Therefore the current that goes through the readout cable is negligible and won't generate an offset. However, the loading may affect the temperature compensation circuit to some extent.

- What is the primary entry point for humidity?

The drying cartridge seal and the silicon glue of the dome are not fully airtight.

8. Trouble shooting

The following contains a procedure for checking the instrument in case it appears that it does not function as it should.

Trouble shooting:

Output signal fails or shows improbable results;

- Check the wires are properly connected to the readout equipment.
- Check the dome, it should be clear and clean. If water is deposited on the inside, please change the desiccant. If too much water is deposited internally the drying cartridge should be removed and the instrument warmed to dry it.
- Check instrument impedance (see specifications for expected values).
- Check data logger or integrator offset by connecting a dummy load (100 Ohm resistor). This should give a "zero" reading.
- Check levelling (bubble inside ring).

If water or ice is deposited on the dome, clean it. Probably water droplets will evaporate in less than one hour under sunlight.

Any visible damage or malfunction should be reported to your distributor, who will suggest appropriate action.

Appendix I Radiometric terminology

Term	Explanation
<i>Azimuth angle</i>	Angle in horizontal direction (0-360°)
<i>Angle of incidence</i>	Incident angle from zenith (vertical)
<i>Cosine response</i>	Detector response according to the cosine law
<i>Global solar irradiance</i>	Total irradiance falling on a horizontal surface (Diffuse + Direct · cos α)
<i>Irradiance</i>	Radiant flux density (W/m ²)
<i>Long-wave radiation</i>	Radiation with wavelengths > 4 μm and < 100 μm
<i>Long-wave downward radiation</i>	Radiation emitted by the sky
<i>Net radiation</i>	Long-wave downward radiation minus outgoing radiation
<i>Pyrgeometer</i>	Radiometer suitable to measure downward long-wave radiation
<i>Short-wave radiation</i>	Radiation with wavelengths > 280 nm and < 4 μm
<i>Thermopile</i>	Thermal detector made up of many thermocouple junctions
<i>WMO</i>	World Meteorological Organisation
<i>WRC</i>	World Radiation Center (in Davos, Switzerland)
<i>Zenith angle</i>	Angle from zenith (0°, vertical)

Appendix II 10kΩ thermistor specifications

YSI Thermistor 44031 - Resistance versus Temperature in °C

Thermistor (10 kΩ @ 25°C)

$$T = (\alpha + [\beta \cdot (\ln(R)) + \gamma \cdot (\ln(R))^3])^{-1} - 273.15$$

$$\alpha : 1.03 \cdot 10^{-3}$$

$$\beta : 2.38 \cdot 10^{-4}$$

$$\gamma : 1.59 \cdot 10^{-7}$$

T [°C] = Temperature R [Ω] = Resistance

YSI 44031 Temperature vs. Resistance											
Temperature			Resistance			Temperature			Resistance		
[°C]	[°F]	[Ohm]	[°C]	[°F]	[Ohm]	[°C]	[°F]	[Ohm]	[°C]	[°F]	[Ohm]
-30	-22.0	135,200	0	32.0	29,490	30	86.0	8,194			
-29	-20.2	127,900	1	33.8	28,150	31	87.8	7,880			
-28	-18.4	121,100	2	35.6	26,890	32	89.6	7,579			
-27	-16.6	114,600	3	37.4	25,690	33	91.4	7,291			
-26	-14.8	108,600	4	39.2	24,550	34	93.2	7,016			
-25	-13.0	102,900	5	41.0	23,460	35	95.0	6,752			
-24	-11.2	97,490	6	42.8	22,430	36	96.8	6,500			
-23	-9.4	92,430	7	44.6	21,450	37	98.6	6,258			
-22	-7.6	87,660	8	46.4	20,520	38	100.4	6,026			
-21	-5.8	83,160	9	48.2	19,630	39	102.2	5,805			
-20	-4.0	78,910	10	50.0	18,790	40	104.0	5,592			
-19	-2.2	74,910	11	51.8	17,980	41	105.8	5,389			
-18	-0.4	71,130	12	53.6	17,220	42	107.6	5,193			
-17	1.4	67,570	13	55.4	16,490	43	109.4	5,006			
-16	3.2	64,200	14	57.2	15,790	44	111.2	4,827			
-15	5.0	61,020	15	59.0	15,130	45	113.0	4,655			
-14	6.8	58,010	16	60.8	14,500	46	114.8	4,489			
-13	8.6	55,170	17	62.6	13,900	47	116.6	4,331			
-12	10.4	52,480	18	64.4	13,330	48	118.4	4,179			
-11	12.2	49,940	19	66.2	12,790	49	120.2	4,033			
-10	14.0	47,540	20	68.0	12,260	50	122.0	3,893			
-9	15.8	45,270	21	69.8	11,770	51	123.8	3,758			
-8	17.6	43,110	22	71.6	11,290	52	125.6	3,629			
-7	19.4	41,070	23	73.4	10,840	53	127.4	3,504			
-6	21.2	39,140	24	75.2	10,410	54	129.2	3,385			
-5	23.0	37,310	25	77.0	10,000	55	131.0	3,270			
-4	24.8	35,570	26	78.8	9,605	56	132.8	3,160			
-3	26.6	33,930	27	80.6	9,227	57	134.6	3,054			
-2	28.4	32,370	28	82.4	8,867	58	136.4	2,952			
-1	30.2	30,890	29	84.2	8,523	59	138.2	2,854			

Appendix III Pt-100 specifications

Pt-100 - Resistance versus Temperature in °C and °F

$$T = \frac{-\alpha + \sqrt{\alpha^2 - 4 \cdot \beta \cdot \left(\frac{-R}{100} + 1\right)}}{2 \cdot \beta}$$

$\alpha : 3.9083 \cdot 10^{-3}$
 $\beta : -5.8019 \cdot 10^{-7}$

T [°C] = Temperature

R [Ω] = Resistance

Pt-100 Temperature vs. Resistance											
Temperature			Resistance			Temperature			Resistance		
[°C]	[°F]	[Ohm]	[°C]	[°F]	[Ohm]	[°C]	[°F]	[Ohm]	[°C]	[°F]	[Ohm]
-30	-22.0	88.2	0	32.0	100.0	30	86.0	111.7			
-29	-20.2	88.6	1	33.8	100.4	31	87.8	112.1			
-28	-18.4	89.0	2	35.6	100.8	32	89.6	112.5			
-27	-16.6	89.4	3	37.4	101.2	33	91.4	112.8			
-26	-14.8	89.8	4	39.2	101.6	34	93.2	113.2			
-25	-13.0	90.2	5	41.0	102.0	35	95.0	113.6			
-24	-11.2	90.6	6	42.8	102.3	36	96.8	114.0			
-23	-9.4	91.0	7	44.6	102.7	37	98.6	114.4			
-22	-7.6	91.4	8	46.4	103.1	38	100.4	114.8			
-21	-5.8	91.8	9	48.2	103.5	39	102.2	115.2			
-20	-4.0	92.2	10	50.0	103.9	40	104.0	115.5			
-19	-2.2	92.6	11	51.8	104.3	41	105.8	115.9			
-18	-0.4	93.0	12	53.6	104.7	42	107.6	116.3			
-17	1.4	93.3	13	55.4	105.1	43	109.4	116.7			
-16	3.2	93.7	14	57.2	105.5	44	111.2	117.1			
-15	5.0	94.1	15	59.0	105.9	45	113.0	117.5			
-14	6.8	94.5	16	60.8	106.2	46	114.8	117.9			
-13	8.6	94.9	17	62.6	106.6	47	116.6	118.2			
-12	10.4	95.3	18	64.4	107.0	48	118.4	118.6			
-11	12.2	95.7	19	66.2	107.4	49	120.2	119.0			
-10	14.0	96.1	20	68.0	107.8	50	122.0	119.4			
-9	15.8	96.5	21	69.8	108.2	51	123.8	119.8			
-8	17.6	96.9	22	71.6	108.6	52	125.6	120.2			
-7	19.4	97.3	23	73.4	109.0	53	127.4	120.6			
-6	21.2	97.7	24	75.2	109.4	54	129.2	120.9			
-5	23.0	98.0	25	77.0	109.7	55	131.0	121.3			
-4	24.8	98.4	26	78.8	110.1	56	132.8	121.7			
-3	26.6	98.8	27	80.6	110.5	57	134.6	122.1			
-2	28.4	99.2	28	82.4	110.9	58	136.4	122.5			
-1	30.2	99.6	29	84.2	110.3	59	138.2	122.9			

Appendix IV List of World and Regional Radiation Centres

World Radiation Centre

The World Radiation Centre capable of pyrgeometer calibration is located at:

Physikalisch-Meteorologisches Observatorium

Dorfstrasse 33 CH-7260
Davos Dorf Switzerland.

Website: www.pmodwrc.ch

Appendix V Recalibration service

Pyranometers, Albedometers, Pyrgeometers, UV-Radiometers & Sunshine Duration Sensors

Kipp & Zonen solar radiation measurement instruments comply with the most demanding international standards. In order to maintain the specified performance of these instruments, Kipp & Zonen recommends calibration of their instruments every two years.

This can be done at the Kipp & Zonen factory. Here, recalibration to the highest standards can be performed at low cost. Recalibration can usually be performed within four weeks. If required, urgent recalibration can be accomplished in three weeks or less (subject to scheduling restrictions). Kipp & Zonen will confirm the duration of recalibration at all times. Please note that special quantity recalibration discounts are available for instruments of the same type.

CUSTOMER SUPPORT

Our customer support remains at your disposal for any maintenance or repair, calibration, supplies and spares. The address is as follows:

Für Servicearbeiten und Kalibrierung, Verbrauchsmaterial und Ersatzteile steht Ihnen unsere Customer Support Abteilung unter folgender Adresse zur Verfügung:

Notre service 'Support Clientèle' reste à votre entière disposition pour tout problème de maintenance, réparation ou d'étalonnage ainsi que pour les accessoires et pièces de rechange. Leur adresse est la suivante :

Holland **Kipp & Zonen B.V.**
Delftechpark 36
2628 XH DELFT
T +31 15 275 5210
F +31 15 262 0351
E info@kippzonen.com

USA **Kipp & Zonen USA Inc.**
125, Wilbur Place
BOHEMIA/NY 11716
T +1 631 589 2065
F +1 631 589 2068
E kipp.usa@kippzonen.com

UK **Kipp & Zonen Ltd.**
P.O. Box 819,
LINCOLN, Lincolnshire LN6 0WY
T +44 1522 695 403
F +44 1522 696 598
E kipp.uk@kippzonen.com

France **Kipp & Zonen S.A.R.L.**
7, avenue Clément Ader
ZA Ponroy - Bât. M
F-94420 LE PLESSIS TREVISE
T +33 1 49 62 4104
F +33 1 49 62 4102
E kipp.france@kippzonen.com

Germany **Gengenbach Messtechnik**
Heinrich-Otto-Strasse 3
D-73262 REICHENBACH/FILS
T +49 7153 9258 0
F +49 7153 9258 160
E info@rg-messtechnik.de



WWW.KIPPZONEN.COM